

Hybrid Passive Copper 100GE QSFP28 to 4x 25GE SFP28 GQS-4P28-P(A)XXC

Features

- ◆ Supporting 100 Gbps to 4 x 25 Gbps
- ◆ Support data rates : 25.78Gb/s (per channel)
- ◆ IEEE 802.3bj 100GEBASE-CR4 and P802.3by compliant
- ◆ Compatible to SFP28 MSA and QSFP28 MSA
- ◆ Compatible to SFF-8402, SFF-8432 and SFF8665
- ◆ Maximum aggregate data rate: 100 Gb/s (4 x 25Gb/s)
- ◆ High-Density QSFP28 38-PIN and 4x SFP28 20-PIN Connector
- ◆ Temperature Range: 0~ 70 °C
- ◆ Copper link length up to 5m
- ◆ Power Supply :+3.3V
- ◆ Low crosstalk
- ◆ I2C based two-wire serial interface for EEPROM signature which can be customized
- ◆ Operating Temperature: 0~ 70 °C
- ◆ ROHS Compliant



Applications

- ◆ 100GE/25 Gigabit Ethernet
- ◆ Switches, Routers, and HBAs
- ◆ Data Centers

Product Description

The 100GE QSFP28 to 4x 25GE SFP28 Passive cable assemblies are high performance, cost effective for SFP28 and QSFP28 equipment interconnects . The Hybrid cables are compliant with SFF-8402 and SFF-8665 specifications. It offer a low power consumption, short reach interconnect applications. The cable each lane is capable of transmitting data at rates up to 25Gb/s, providing an aggregated rate of 100Gb/s.

Recommended Operating Conditions

Parameter	Symbol	Min	Typical	Max	Unit
Storage Ambient Temperature		-40		+85	°C
Operating Case Temperature	T _c	0		+70	°C
Power Supply Voltage	V _{CC3}	3.14	3.3	3.47	V

High Speed Characteristics

Parameter	Symbol	Min	Typical	Max	Unit	Note
Differential Impedance	RIN,P-P	90		110	Ω	
Insertion loss	SDD21			22.48	dB	At 12.8906 GHz
Differential Return Loss	SDD11			See 1	dB	At 0.05 to 4.1 GHz
	SDD22			See 2	dB	At 4.1 to 19 GHz
Common-mode to common-mode output return loss	SCC11	2			dB	At 0.2 to 19 GHz
	SCC22					
Differential to common-mode return loss	SCD11			See 3	dB	At 0.01 to 12.89 GHz
	SCD22			See 4		At 12.89 to 19 GHz
Differential to common Mode Conversion Loss	SCD21			10	dB	At 0.01 to 12.89 GHz
				See 5		At 12.89 to 15.7 GHz
				6.3		At 15.7 to 19 GHz
Channel Operating Margin	COM	3			dB	

Notes:

1. Reflection Coefficient given by equation $SDD11(dB) < 16.5 - 2 \times \text{SQRT}(f)$, with f in GHz
2. Reflection Coefficient given by equation $SDD11(dB) < 10.66 - 14 \times \log_{10}(f/5.5)$, with f in GHz
3. Reflection Coefficient given by equation $SCD11(dB) < 22 - (20/25.78)^*f$, with f in GHz
4. Reflection Coefficient given by equation $SCD11(dB) < 15 - (6/25.78)^*f$, with f in GHz
5. Reflection Coefficient given by equation $SCD21(dB) < 27 - (29/22)^*f$, with f in GHz

Mechanical Dimensions

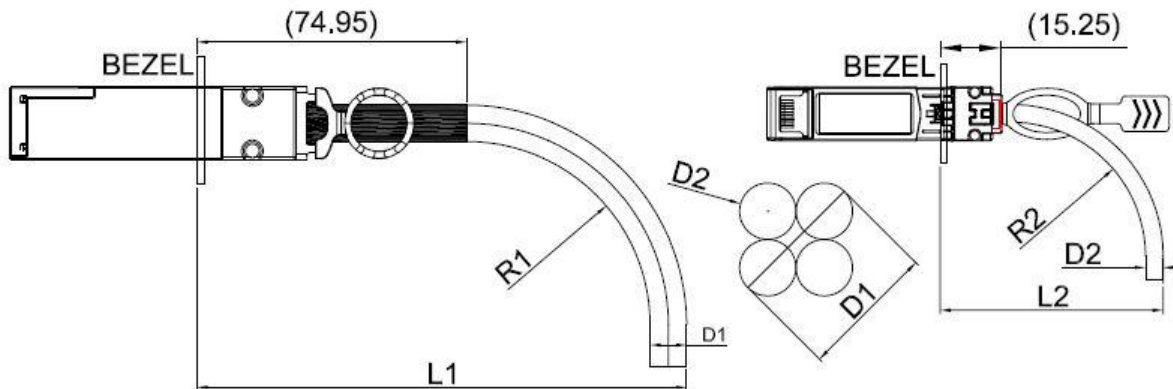
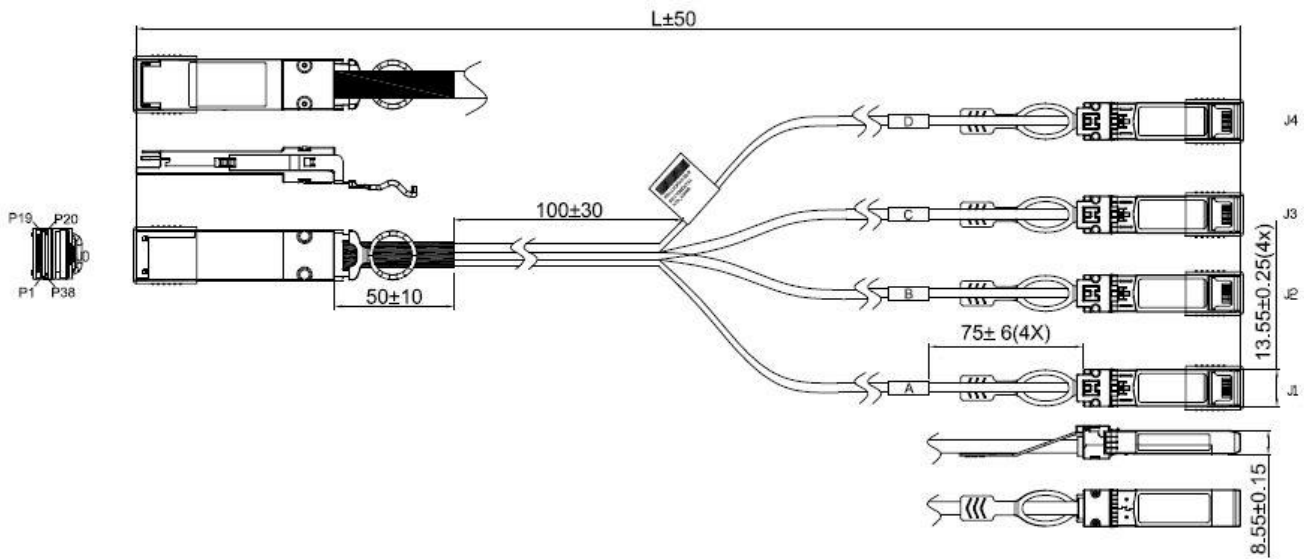

QSFP28			
CABLE GAUGE	DIAMETER "D1"	MIN.BEND RADIUS "R1"	MIN.BEND SPACE "L1"
30AWG	10.9MM	54.5MM	140.35MM
28AWG	11.4MM	57MM	143.35MM
26AWG	12.6MM	63MM	150.55MM
24AWG	14.1MM	70.5MM	159.55MM

SFP28			
CABLE GAUGE	DIAMETER "D2"	MIN.BEND RADIUS "R2"	MIN.BEND SPACE "L2"
30AWG	4.5MM	22.5MM	42.25MM
28AWG	4.7MM	23.5MM	43.45MM
26AWG	5.2MM	26MM	46.45MM
24AWG	5.8MM	29MM	50.05MM

QSFP28 Pin Descriptions

Pin	Logic	Symbol	Name/Description	Notes
1		GND	Ground	1

2	CML-I	Tx2n	Transmitter Inverted Data Input	
3	CML-I	Tx2p	Transmitter Non-Inverted Data Input	
4		GND	Ground	1
5	CML-I	Tx4n	Transmitter Inverted Data Input	
6	CML-I	Tx4p	Transmitter Non-Inverted Data Input	
7		GND	Ground	1
8	LVTTL-I	ModSelL	Module Select	
9	LVTTL-I	ResetL	Module Reset	
10		Vcc Rx	+3.3V Power Supply Receiver	2
11	LVC MOSI/O	SCL	2-wire serial interface clock	
12	LVC MOSI/O	SDA	2-wire serial interface data	
13		GND	Ground	1
14	CML-O	Rx3p	Receiver Non-Inverted Data Output	
15	CML-O	Rx3n	Receiver Inverted Data Output	
16		GND	Ground	1
17	CML-O	Rx1p	Receiver Non-Inverted Data Output	
18	CML-O	Rx1n	Receiver Inverted Data Output	
19		GND	Ground	1
20		GND	Ground	1
21	CML-O	Rx2n	Receiver Inverted Data Output	
22	CML-O	Rx2p	Receiver Non-Inverted Data Output	
23		GND	Ground	1
24	CML-O	Rx4n	Receiver Inverted Data Output	
25	CML-O	Rx4p	Receiver Non-Inverted Data Output	
26		GND	Ground	1
27	LVTTL-O	ModPrsL	Module Present	
28	LVTTL-O	IntL	Interrupt	
29		Vcc Tx	+3.3V Power supply transmitter	2
30		Vcc1	+3.3V Power supply	2
31	LVTTL-I	LPMode	Low Power Mode	
32		GND	Ground	1
33	CML-I	Tx3p	Transmitter Non-Inverted Data Input	
34	CML-I	Tx3n	Transmitter Inverted Data Input	
35		GND	Ground	1
36	CML-I	Tx1p	Transmitter Non-Inverted Data Input	
37	CML-I	Tx1n	Transmitter Inverted Data Input	
38		GND	Ground	1

Note 1: GND is the symbol for signal and supply (power) common for the QSFP28 module. All are common within the QSFP28 module and all module voltages are referenced to this potential unless otherwise noted. Connect these directly to the host board signal-common ground plane.

Note 2: Vcc Rx, Vcc1 and Vcc Tx are the receiver and transmitter power supplies and shall be applied concurrently. Requirements defined for the host side of the Host Edge Card Connector are listed in

Table 6. Recommended host board power supply filtering is shown in Figure 4. Vcc Rx Vcc1 and Vcc Tx may be internally connected with- in the QSFP28 Module module in any combination. The connector pins are each rated for a maximum current of 500 mA.

SFP28 Pin Descriptions

Pin	Logic	Symbol	Name/Description	Notes
1		VeeT	Transmitter Ground	
2	LV-TTL-O	TX_Fault	N/A	1
3	LV-TTL-I	TX_DIS	Transmitter Disable	2
4	LV-TTL-I/O	SDA	Tow Wire Serial Data	
5	LV-TTL-I	SCL	Tow Wire Serial Clock	
6		MOD_DEF0	Module present, connect to VeeT	
7	LV-TTL-I	RS0	N/A	1
8	LV-TTL-O	LOS	LOS of Signal	2
9	LV-TTL-I	RS1	N/A	1
10		VeeR	Reciever Ground	
11		VeeR	Reciever Ground	
12	CML-O	RD-	Reciever Data Inverted	
13	CML-O	RD+	Reciever Data Non-Inverted	
14		VeeR	Reciever Ground	
15		VccR	Reciever Supply 3.3V	
16		VccT	Transmitter Supply 3.3V	
17		VeeT	Transmitter Ground	
18	CML-I	TD+	Transmitter Data Non-Inverted	
19	CML_I	TD-	Transmitter Data Inverted	
20		VeeT	Transmitter Ground	

1. Signals not supported in SFP28 Copper pulled-down to VeeT with 30K ohms resistor
2. Passive cable assemblies do not support LOS and TX_DIS

Ordering information

Part Number	GQS-4P28-P(A)XXC				
Length (meter)	1	2	3	4	5
Wire gauge (AWG)	30	30	26	26	26

Important Notice

Performance figures, data and any illustrative material provided in this data sheet are typical and must

be specifically confirmed in writing by GIGALIGHT before they become applicable to any particular order or contract. In accordance with the GIGALIGHT policy of continuous improvement specifications may change without notice. The publication of information in this data sheet does not imply freedom from patent or other protective rights of GIGALIGHT or others. Further details are available from any GIGALIGHT sales representative.

Shenzhen Gigalight Technology Co., Ltd

Email: sales@gigalight.com.cn

<http://www.gigalight.com>

Revision History

Version	Date	Description
V0	Mar-2016	New release
V1	26-Mar-2019	Change copper link length from 'up to 3m' to 'up tp 5m'