

GIGALIGHT Multi-rate 100G QSFP28 LR4 Optical Transceiver Module

P/N: GQS-SPO111-LR4CA

Features

- ◆ 4 channels full-duplex transceiver modules
- ◆ Transmission data rate up to 28Gbps per channel
- ◆ 4 x 28Gb/s DFB-based LAN-WDM Cooling transmitter
- ◆ 4 channels PIN ROSA
- ◆ Internal CDR circuits on both receiver and transmitter channels
- ◆ Low power consumption <3.5W
- ◆ Hot Pluggable QSFP form factor
- ◆ Up to reach 10km for G.652 SMF
- ◆ Duplex LC receptacles
- ◆ Operating case temperature 0°C to +70°C
- ◆ 3.3V power supply voltage
- ◆ RoHS compliant(lead free)



Applications

- ◆ IEEE 802.3ba 100GBASE LR4
- ◆ OTN OTU4 and 100GE

Description

This product is a 100Gb/s transceiver module designed for optical communication applications compliant to 100GBASE-LR4 of the IEEE P802.3ba standard and OTU4 411-9D1F requirements specified in ITU-T Recommendations G.959.1/G.709 and Supplement 39(G.sup39). The module converts 4 input channels of 28Gb/s electrical data to 4 channels of LAN WDM optical signals and then multiplexes them into a single channel for 100Gb/s optical transmission. Reversely on the receiver side, the module de-multiplexes a 100Gb/s optical input into 4 channels of LAN WDM optical signals and then converts them to 4 output channels of electrical data.

The central wavelengths of the 4 LAN WDM channels are 1295.56, 1300.05, 1304.58 and 1309.14 nm as members of the LAN WDM wavelength grid defined in IEEE 802.3ba. The high performance cooled LAN WDM DFB transmitters and high sensitivity PIN receivers provide superior performance for 100Gigabit Ethernet applications up to 10km links and compliant to optical interface with IEEE802.3ba Clause 88 100GBASE-LR4 requirements.

The product is designed with form factor, optical/electrical connection and digital diagnostic interface according to the QSFP+ Multi-Source Agreement (MSA). It has been designed to meet the harshest external operating conditions including temperature, humidity and EMI interference.

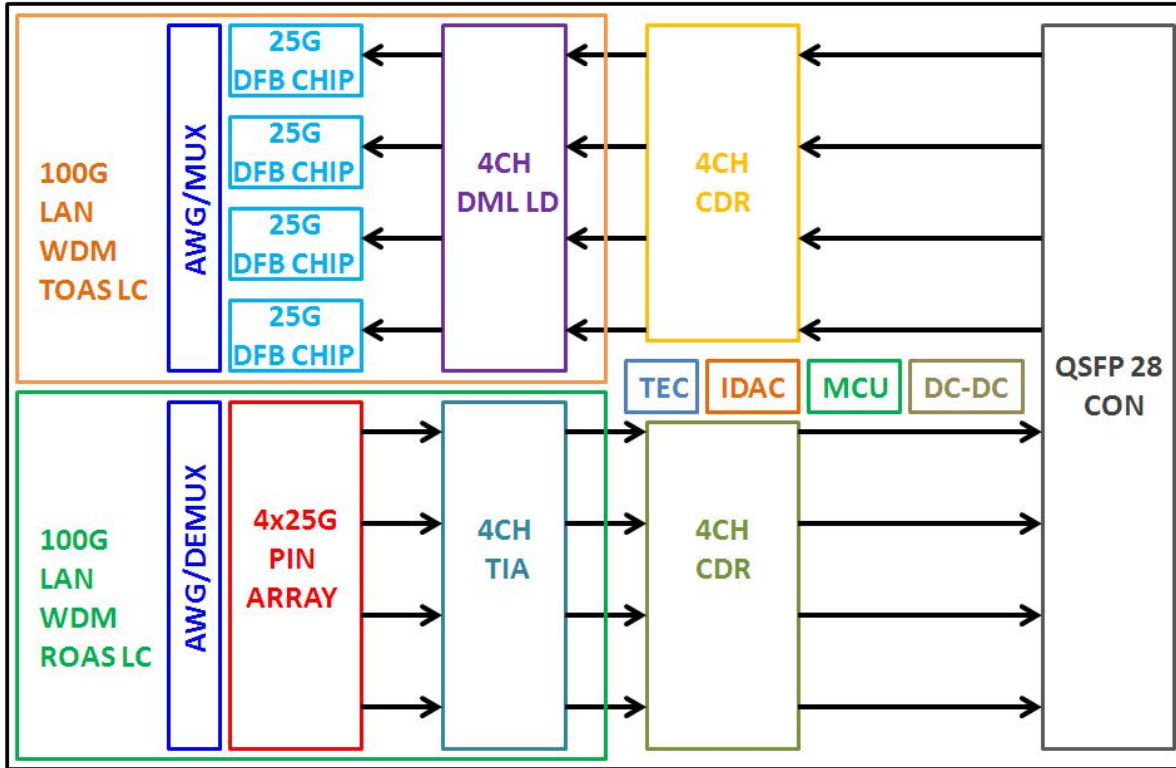

Figure1. Module Block Diagram

Absolute Maximum Ratings

Parameter	Symbol	Min	Max	Unit
Supply Voltage	Vcc	-0.3	3.6	V
Input Voltage	Vin	-0.3	Vcc+0.3	V
Storage Temperature	Tst	-20	85	°C
Case Operating Temperature	Top	0	70	°C
Humidity(non-condensing)	Rh	5	85	%
Damage Threshold, each Lane	TH	5.5		dBm

Recommended Operating Conditions

Parameter	Symbol	Min	Typical	Max	Unit
Supply Voltage	Vcc	3.13	3.3	3.47	V
Operating Case temperature	Tca	0		70	°C
Data Rate Per Lane	fd			28	Gbps
Humidity	Rh	5		85	%
Power Dissipation	P			3.5	W
Link Distance with G.652	D	0.002		10	km

Electrical Specifications

Parameter	Symbol	Min	Typical	Max	Unit
Power Consumption	P			3.5	W
Supply Current	Icc			1.06	A
Transceiver Power-on Initialization Time				2000	ms
Transmitter(each Lane)					
Single-ended Input Voltage Tolerance		-0.3		4.0	V
AC Common Mode Input Voltage Tolerance		15			mV
Differential Input Voltage		50			mVpp
Differential Input Voltage Swing	Vin			900	mVpp
Differential Input Impedance	Zin	90	100	110	Ohm
Receiver(each Lane)					
Single-ended Output Voltage		-0.3		4.0	V

Parameter	Symbol	Min	Typical	Max	Unit
AC Common Mode Output Voltage				7.5	mV
Differential Output Voltage Swing	Vout	300		850	mVpp
Differential Output Impedance	Zout	90	100	110	Ohm

Note:

Power-on Initialization Time is the time from when the power supply voltages reach and remain above the minimum recommended operating supply voltages to the time when the module is fully functional.

Optical Characteristics

Table 3 - Optical Characteristics 100GBASE-LR4

QSFP28 100GBASE-LR4						
Parameter	Symbol	Min	Typical	Max	Unit	Notes
Lane Wavelength	L0	1294.53	1295.56	1296.59	nm	
	L1	1299.02	1300.05	1301.09	nm	
	L2	1303.54	1304.58	1305.63	nm	
	L3	1308.09	1309.14	1310.19	nm	
Transmitter						
SMSR	SMSR	30			dB	
Total Average Launch Power	P _T			10.5	dBm	
Average Launch Power, each Lane	P _{AVG}	-4.3		4.5	dBm	
OMA, each Lane	P _{OMA}	-1.3		4.5	dBm	1
Difference in Launch Power between any Two Lanes (OMA)	P _{tx,diff}			5	dB	
Launch Power in OMA minus Transmitter and Dispersion		-2.3			dBm	

QSFP28 100GBASE-LR4						
Parameter	Symbol	Min	Typical	Max	Unit	Notes
Penalty (TDP), each Lane						
TDP, each Lane	TDP			2.2	dB	
Extinction Ratio	ER	4			dB	
RIN _{20OMA}	RIN			-130	dB/Hz	
Optical Return Loss Tolerance	TOL			20	dB	
Transmitter Reflectance	R _T			-12	dB	
Eye Mask coordinates: X1, X2, X3, Y1, Y2, Y3		{0.25, 0.4, 0.45, 0.25, 0.28, 0.4}				2
Average Launch Power OFF Transmitter, each Lane	Poff			-30	dBm	
Receiver						
Damage Threshold, each Lane	TH _d	5.5			dBm	3
Total Average Receive Power				10.5	dBm	
Average Receive Power, each Lane		-10.6		4.5	dBm	
Receive Power (OMA), each Lane				4.5	dBm	
Receiver Sensitivity (OMA), each Lane	SEN			-8.6	dBm	
Stressed Receiver Sensitivity (OMA), each Lane				-6.8	dBm	4
Difference in Receive Power between any Two Lanes (OMA)	Prx,diff			5.5	dB	
LOS Assert	LOSA		-18		dBm	
LOS Deassert	LOSD		-15		dBm	

QSFP28 100GBASE-LR4						
Parameter	Symbol	Min	Typical	Max	Unit	Notes
LOS Hysteresis	LOSH	0.5			dB	
Receiver Electrical 3 dB upper Cutoff Frequency, each Lane	Fc			31	GHz	
Conditions of Stress Receiver Sensitivity Test (Note 5)						
Vertical Eye Closure Penalty, each Lane			1.8		dB	5
Stressed Eye J2 Jitter, each Lane			0.3		UI	
Stressed Eye J9 Jitter, each Lane			0.47		UI	

Note:

1. Even if the TDP < 1 dB, the OMA min must exceed the minimum value specified here.
2. See Figure 4 below.
3. The receiver shall be able to tolerate, without damage, continuous exposure to a modulated optical input signal having this power level on one lane. The receiver does not have to operate correctly at this input power.
4. Measured with conformance test signal at receiver input for BER = 1×10^{-12} .
5. Vertical eye closure penalty and stressed eye jitter are test conditions for measuring stressed receiver sensitivity. They are not characteristics of the receiver.

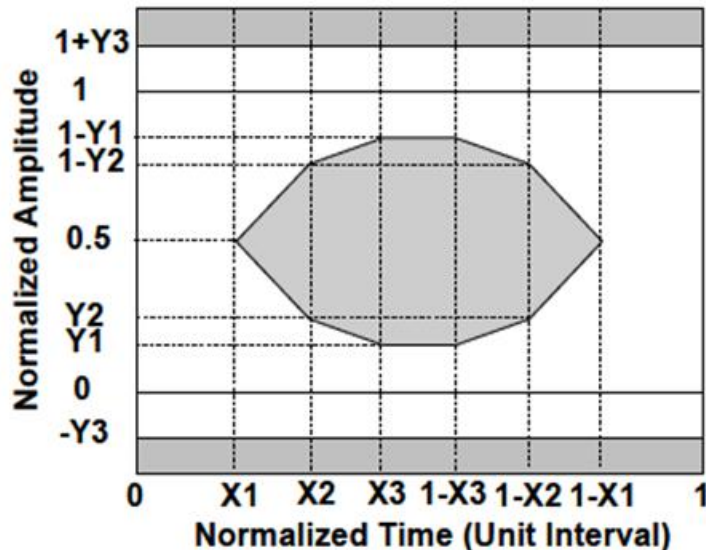

OTU4 4I1-9D1F Operation

QSFP28 100GBASE-LR4						
Parameter	Symbol	Min	Typical	Max	Unit	Notes
Signaling Speed per Channel			27.9525+/- 20ppm		GBd	1
Lane Wavelength	L0	1294.53	1295.56	1296.59	nm	
	L1	1299.02	1300.05	1301.09	nm	
	L2	1303.54	1304.58	1305.63	nm	
	L3	1308.09	1309.14	1310.19	nm	
Transmitter						
Total Average Launch Power	P _T			10	dBm	
Average Launch Power, each Lane	P _{AVG}	-0.6		4.0	dBm	
Difference in Launch Power between any Two Lanes (OMA)	P _{tx,diff}			5	dB	
Extinction Ratio	ER	4		6.5	dB	
Optical Return Loss Tolerance	TOL			20	dB	
Transmitter Reflectance	R _T			-12	dB	
Eye Mask coordinates: X1, X2, X3, Y1, Y2, Y3		{0.25, 0.4, 0.45, 0.25, 0.28, 0.4}				2
Average Launch Power OFF Transmitter, each Lane	P _{off}			-30	dBm	
Receiver						
Signaling Speed per Channel			27.9525+/- 20ppm		GBd	3
Total Average Receive Power				10	dBm	

QSFP28 100GBASE-LR4						
Parameter	Symbol	Min	Typical	Max	Unit	Notes
Average Receive Power, each Lane		-6.9		4.0	dBm	4
Optical Path Penalty	OPP			1.5	dBm	
Equivalent Sensitivity, each Lane	SEN			-8.4	dBm	4
LOS Assert	LOSA			-11.6	dBm	
LOS Deassert	LOSD			-13.6	dBm	
LOS Hysteresis	LOSH	0.5			dB	

Notes:

1. Transmitter consists of 4 lasers operating at 27.95G/s each.
2. Hit ratio 5×10^{-5} .
3. Receiver consists of 4 photodetectors operating at 27.95Gb/s each.
4. Specified at a BER of 10^{-6} (Pre-FEC),per ITU-T G.sup39.

Pin Descriptions

Pin	Logic	Symbol	Name/Description	Ref.
1		GND	Module Ground	1
2	CML-I	Tx2-	Transmitter inverted data input	
3	CML-I	Tx2+	Transmitter non-inverted data input	
4		GND	Module Ground	1
5	CML-I	Tx4-	Transmitter inverted data input	
6	CML-I	Tx4+	Transmitter non-inverted data input	
7		GND	Module Ground	1
8	LVTTL-I	MODSEIL	Module Select	2

Pin	Logic	Symbol	Name/Description	Ref.
9	LVTTL-I	ResetL	Module Reset	2
10		VCCRx	+3.3v Receiver Power Supply	
11	LVC MOS-I	SCL	2-wire Serial interface clock	2
12	LVC MOS-I/O	SDA	2-wire Serial interface data	2
13		GND	Module Ground	1
14	CML-O	RX3+	Receiver non-inverted data output	
15	CML-O	RX3-	Receiver inverted data output	
16		GND	Module Ground	1
17	CML-O	RX1+	Receiver non-inverted data output	
18	CML-O	RX1-	Receiver inverted data output	
19		GND	Module Ground	1
20		GND	Module Ground	1
21	CML-O	RX2-	Receiver inverted data output	
22	CML-O	RX2+	Receiver non-inverted data output	
23		GND	Module Ground	1
24	CML-O	RX4-	Receiver inverted data output	
25	CML-O	RX4+	Receiver non-inverted data output	
26		GND	Module Ground	1
27	LVTTL-O	ModPrsL	Module Present, internal pulled down to GND	
28	LVTTL-O	IntL	Interrupt output, should be pulled up on host board	2

Pin	Logic	Symbol	Name/Description	Ref.
29		VCCTx	+3.3v Transmitter Power Supply	
30		VCC1	+3.3v Power Supply	
31	LVTTL-I	LPMODE	Low Power Mode	2
32		GND	Module Ground	1
33	CML-I	Tx3+	Transmitter non-inverted data input	
34	CML-I	Tx3-	Transmitter inverted data input	
35		GND	Module Ground	1
36	CML-I	Tx1+	Transmitter non-inverted data input	
37	CML-I	Tx1-	Transmitter inverted data input	
38		GND	Module Ground	1

Notes:

1. Module circuit ground is isolated from module chassis ground within the module.
2. Open collector; should be pulled up with 4.7k – 10k ohms on host board to a voltage between 3.15V and 3.6V.

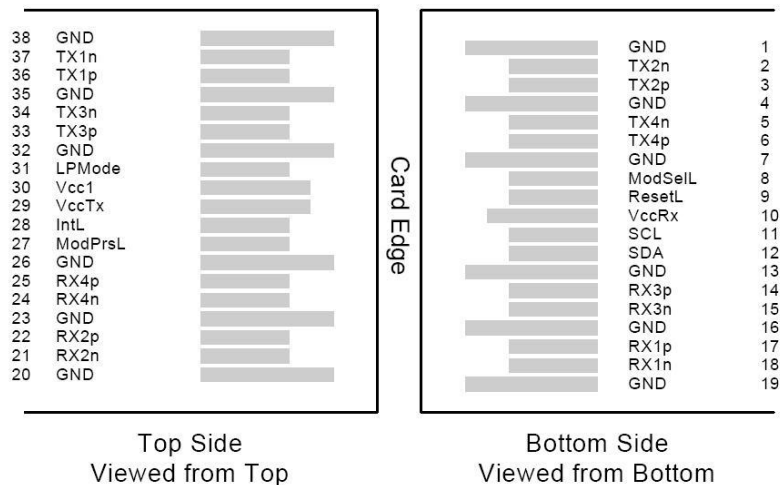

Figure 2. Electrical Pin-out Details

ModSelL Pin

The ModSelL is an input pin. When held low by the host, the module responds to 2-wire serial communication commands. The ModSelL allows the use of multiple QSFP modules on a single 2-wire interface bus. When the ModSelL is “High”, the module will not respond to any 2-wire interface communication from the host. ModSelL has an internal pull-up in the module.

ResetL Pin

Reset. LPMoDe_Reset has an internal pull-up in the module. A low level on the ResetL pin for longer than the minimum pulse length (t_{Reset_init}) initiates a complete module reset, returning all user module settings to their default state. Module Reset Assert Time (t_{init}) starts on the rising edge after the low level on the ResetL pin is released. During the execution of a reset (t_{init}) the host shall disregard all status bits until the module indicates a completion of the reset interrupt. The module indicates this by posting an IntL signal with the Data_Not_Ready bit negated. Note that on power up (including hot insertion) the module will post this completion of reset interrupt without requiring a reset.

LPMoDe Pin

Gigalight QSFP28 LR4 operate in the low power mode (less than 1.5 W power consumption)

This pin active high will decrease power consumption to less than 1W.

ModPrsL Pin

ModPrsL is pulled up to Vcc on the host board and grounded in the module. The ModPrsL is asserted “Low” when the module is inserted and deasserted “High” when the module is physically absent from the host connector.

IntL Pin

IntL is an output pin. When “Low”, it indicates a possible module operational fault or a status critical to the host system. The host identifies the source of the interrupt by using the 2-wire serial interface. The IntL pin is an open collector output and must be pulled up to Vcc on the host board.

Power Supply Filtering

The host board should use the power supply filtering shown in Figure3.

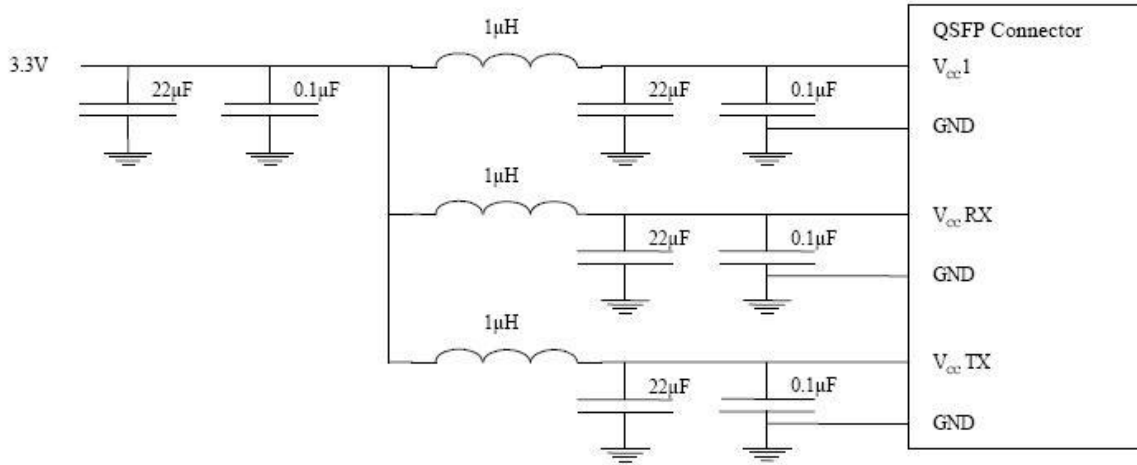

Figure3. Host Board Power Supply Filtering

DIAGNOSTIC MONITORING INTERFACE (OPTIONAL)

The following digital diagnostic characteristics are defined over the normal operating conditions unless otherwise specified.

Parameter	Symbol	Min	Max	Units	Notes
Temperature monitor absolute error	DMI_Temp	-3	+3	degC	Over operating temperature range
Supply voltage monitor absolute error	DMI_VCC	-0.1	0.1	V	Over full operating range
Channel RX power monitor absolute error	DMI_RX_Ch	-2	2	dB	1
Channel Bias current monitor	DMI_Ibias_Ch	-10%	10%	mA	
Channel TX power monitor absolute error	DMI_TX_Ch	-2	2	dB	1

Notes:

Due to measurement accuracy of different single mode fibers, there could be an additional +/- 1 dB fluctuation, or a +/- 3 dB total accuracy.

Digital diagnostics monitoring function is available on all Gigalight QSFP28 LR4. A 2-wire serial interface provides user to contact with module.

The structure of the memory is shown in Figure 5. The memory space is arranged into a lower, single page, address space of 128 bytes and multiple upper address space pages. This structure permits timely access to addresses in the lower page, such as Interrupt Flags and Monitors. Less time critical time entries, such as serial ID information and threshold settings, are available with the Page Select function.

The interface address used is A0xh and is mainly used for time critical data like interrupt handling in order to enable a one-time-read for all data related to an interrupt situation. After an interrupt, IntL, has been asserted, the host can read out the flag field to determine the affected channel and type of flag.

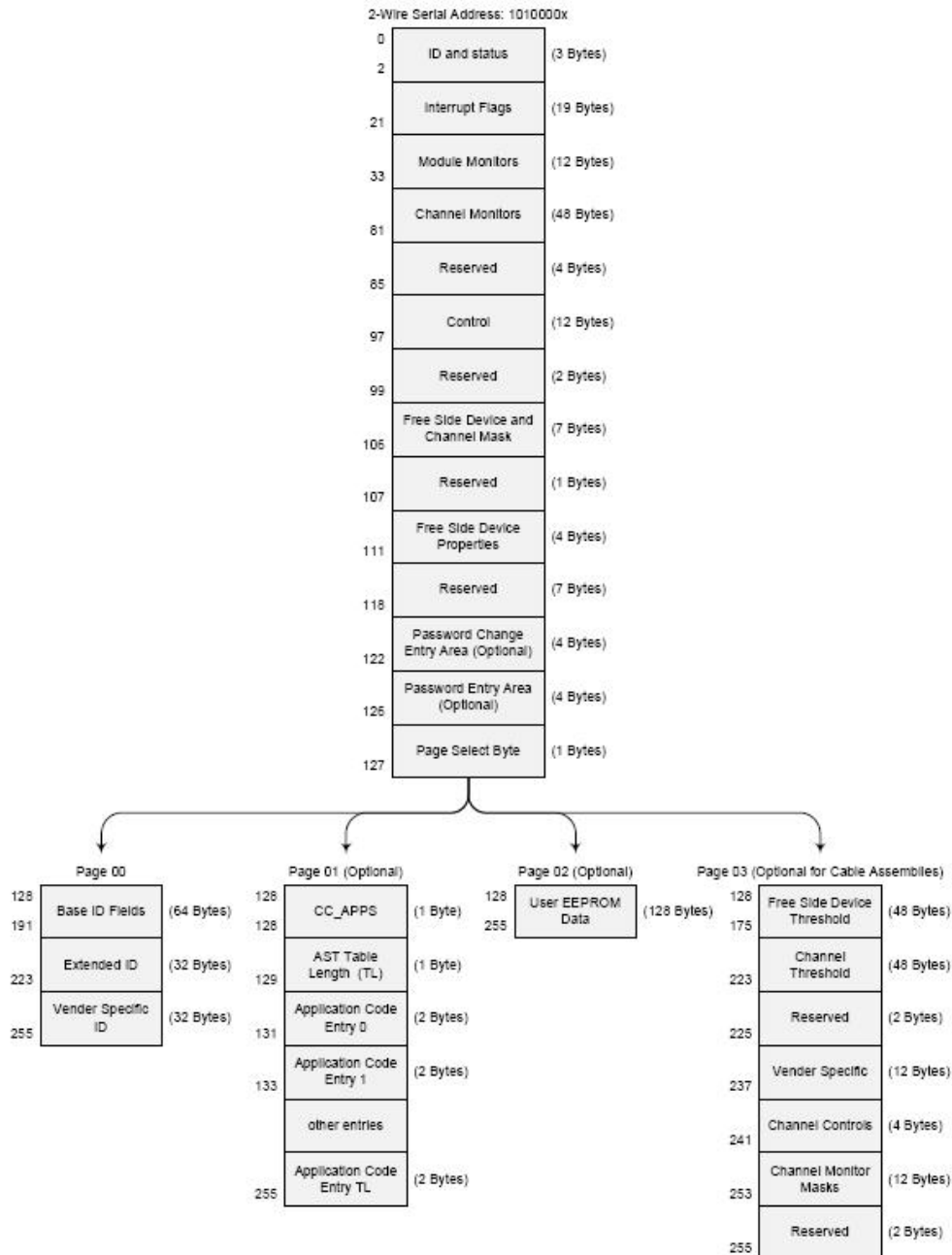

Figure5. QSFP Memory Map

Byte Address	Description	Type
0	Identifier (1 Byte)	Read Only
1-2	Status (2 Bytes)	Read Only
3-21	Interrupt Flags (31 Bytes)	Read Only
22-33	Module Monitors (12 Bytes)	Read Only
34-81	Channel Monitors (48 Bytes)	Read Only
82-85	Reserved (4 Bytes)	Read Only
86-97	Control (12 Bytes)	Read/Write
98-99	Reserved (2 Bytes)	Read/Write
100-106	Module and Channel Masks (7 Bytes)	Read/Write
107-118	Reserved (12 Bytes)	Read/Write
119-122	Reserved (4 Bytes)	Read/Write
123-126	Reserved (4 Bytes)	Read/Write
127	Page Select Byte	Read/Write

Figure6. Low Memory Map

Byte Address	Description	Type
128-175	Module Thresholds (48 Bytes)	Read Only
176-223	Reserved (48 Bytes)	Read Only
224-225	Reserved (2 Bytes)	Read Only
226-239	Reserved (14 Bytes)	Read/Write
240-241	Channel Controls (2 Bytes)	Read/Write
242-253	Reserved (12 Bytes)	Read/Write
254-255	Reserved (2 Bytes)	Read/Write

Figure7. Page 03 Memory Map

Address	Name	Description
128	Identifier (1 Byte)	Identifier Type of serial transceiver
129	Ext. Identifier (1 Byte)	Extended identifier of serial transceiver
130	Connector (1 Byte)	Code for connector type
131-138	Transceiver (8 Bytes)	Code for electronic compatibility or optical compatibility
139	Encoding (1 Byte)	Code for serial encoding algorithm
140	BR, nominal (1 Byte)	Nominal bit rate, units of 100 Mbits/s
141	Extended RateSelect Compliance (1 Byte)	Tags for Extended RateSelect compliance
142	Length SMF (1 Byte)	Link length supported for SM fiber in km
143	Length E-50 μm (1 Byte)	Link length supported for EBW 50/125 μm fiber, units of 2 m
144	Length 50 μm (1 Byte)	Link length supported for 50/125 μm fiber, units of 1 m
145	Length 62.5 μm (1 Byte)	Link length supported for 62.5/125 μm fiber, units of 1 m
146	Length copper (1 Byte)	Link length supported for copper, units of 1 m
147	Device Tech (1 Byte)	Device technology
148-163	Vendor name (16 Bytes)	QSFP vendor name (ASCII)
164	Extended Transceiver (1 Byte)	Extended Transceiver Codes for InfiniBand [†]
165-167	Vendor OUI (3 Bytes)	QSFP vendor IEEE vendor company ID
168-183	Vendor PN (16 Bytes)	Part number provided by QSFP vendor (ASCII)
184-185	Vendor rev (2 Bytes)	Revision level for part number provided by vendor (ASCII)
186-187	Wavelength (2 Bytes)	Nominal laser wavelength (Wavelength = value / 20 in nm)
188-189	Wavelength Tolerance (2 Bytes)	Guaranteed range of laser wavelength (+/- value) from Nominal wavelength (Wavelength Tol. = value / 200 in nm)
190	Max Case Temp (1 Byte)	Maximum Case Temperature in Degrees C
191	CC_BASE (1 Byte)	Check code for Base ID fields (addresses 128-190)
192-195	Options (4 Bytes)	Rate Select, TX Disable, TX Fault, LOS
196-211	Vendor SN (16 Bytes)	Serial number provided by vendor (ASCII)
212-219	Date code (8 Bytes)	Vendor's manufacturing date code
220	Diagnostic Monitoring Type (1 Byte)	Indicates which type of diagnostic monitoring is implemented
221	Enhanced Options (1 Byte)	Indicates which optional enhanced features are implemented
222	Reserved (1 Byte)	Reserved
223	CC_EXT	Check code for the Extended ID Fields (addresses 192-222)
224-255	Vendor Specific (32 Bytes)	Vendor Specific EEPROM

Figure8. Page 00 Memory Map

Page02 is User EEPROM and its format decided by user.

The detail description of low memory and page00.page03 upper memory please see SFF-8436 document.

Timing for Soft Control and Status Functions

Parameter	Symbol	Max	Unit	Conditions
Initialization Time	t_init	2000	ms	Time from power on ¹ , hot plug or rising edge of Reset until the module is fully functional ²
Reset Init Assert Time	t_reset_init	2	μs	A Reset is generated by a low level longer than the minimum reset pulse time present on the ResetL pin.
Serial Bus Hardware Ready Time	t_serial	2000	ms	Time from power on ¹ until module responds to data transmission over the 2-wire serial bus
Monitor Data Ready Time	t_data	2000	ms	Time from power on ¹ to data not ready, bit 0 of Byte 2, deasserted and IntL asserted
Reset Assert Time	t_reset	2000	ms	Time from rising edge on the ResetL pin until the module is fully functional ²
LPMODE Assert Time	ton_LPMODE	100	μs	Time from assertion of LPMODE (Vin:LPMODE = Vih) until module power consumption enters lower Power Level
IntL Assert Time	ton_IntL	200	ms	Time from occurrence of condition triggering IntL until Vout:IntL = Vol
IntL Deassert Time	toff_IntL	500	μs	Time from clear on read ³ operation of associated flag until Vout:IntL = Voh. This includes deassert times for Rx LOS, Tx Fault and other flag bits.
Rx LOS Assert Time	ton_los	100	ms	Time from Rx LOS state to Rx LOS bit set and IntL asserted
Tx Fault Assert Time	ton_Txfault	200	ms	Time from Tx Fault state to Tx Fault bit set and IntL asserted
Flag Assert Time	ton_flag	200	ms	Time from occurrence of condition triggering flag to associated flag bit set and IntL asserted
Mask Assert Time	ton_mask	100	ms	Time from mask bit set ⁴ until associated IntL assertion is inhibited
Mask Deassert Time	toff_mask	100	ms	Time from mask bit cleared ⁴ until associated IntL operation resumes
ModSelL Assert Time	ton_ModSelL	100	μs	Time from assertion of ModSelL until module responds to data transmission over the 2-wire serial bus
ModSelL Deassert Time	toff_ModSelL	100	μs	Time from deassertion of ModSelL until the module does not respond to data transmission over the 2-wire serial bus
Power_override or Power-set Assert Time	ton_Pdown	100	ms	Time from P_Down bit set ⁴ until module power consumption enters lower Power Level
Power_override or Power-set Deassert Time	toff_Pdown	300	ms	Time from P_Down bit cleared ⁴ until the module is fully functional ³

Figure9. Timing Specifications

Note:

1. Power on is defined as the instant when supply voltages reach and remain at or above the minimum specified value.
2. Fully functional is defined as IntL asserted due to data not ready bit, bit 0 byte 2 deasserted.
3. Measured from falling clock edge after stop bit of read transaction.

4. Measured from falling clock edge after stop bit of write transaction.

Mechanical Dimensions

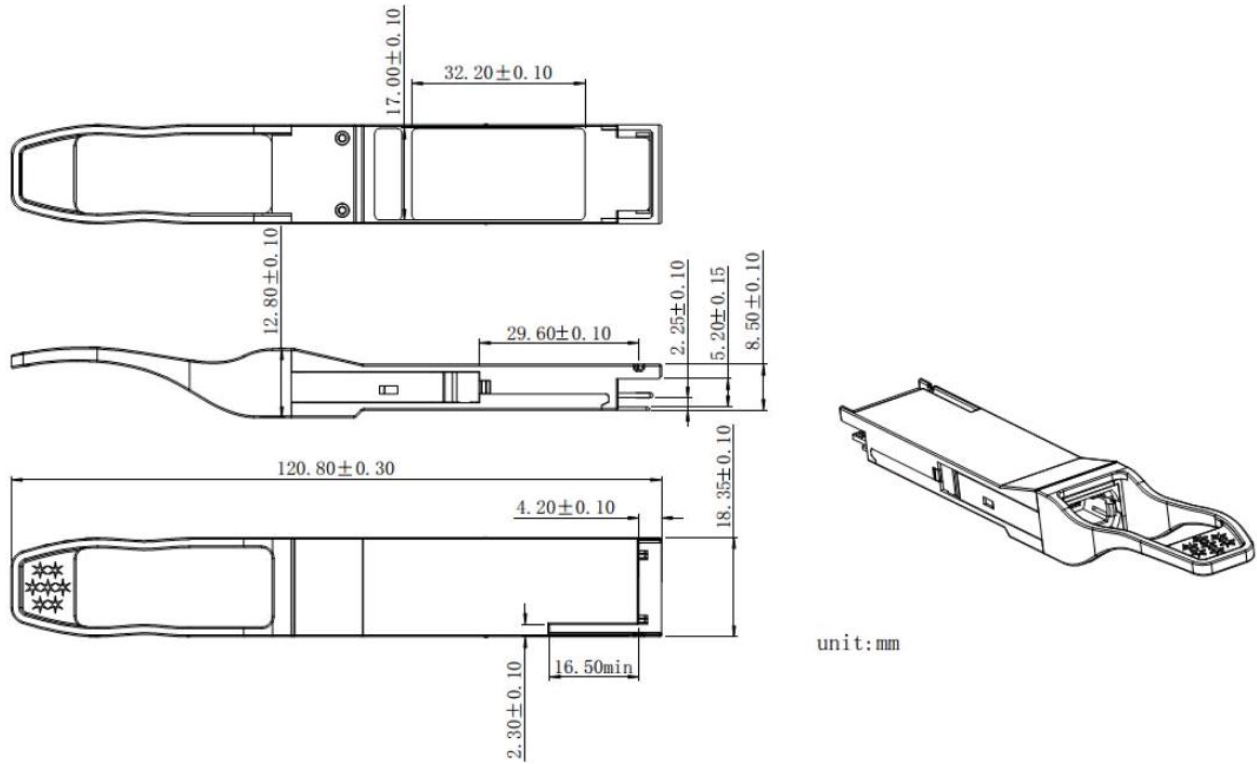

Figure10. Mechanical Specifications

Regulatory Compliance

Gigalight GQS-SPO111-LR4CA transceivers are Class 1 Laser Products. They meet the requirements of the following standards.

Feature	Standard
Laser Safety	IEC 60825-1:2014 (3 rd Edition) IEC 60825-2:2004/AMD2:2010 EN 60825-1:2014 EN 60825-2:2004+A1+A2
Electrical Safety	EN 62368-1: 2014 IEC 62368-1:2014 UL 62368-1:2014
Environmental protection	Directive 2011/65/EU with amendment(EU)2015/863
CE EMC	EN55032: 2015 EN55035: 2017 EN61000-3-2:2014 EN61000-3-3:2013

Feature	Standard
FCC	FCC Part 15, Subpart B ANSI C63.4-2014

ESD

This transceiver is specified as ESD threshold 1kV for SFI pins and 2kV for all other electrical input pins, tested per MIL-STD-883, Method 3015.4 /JESD22-A114-A (HBM). However, normal ESD precautions are still required during the handling of this module. This transceiver is shipped in ESD protective packaging. It should be removed from the packaging and handled only in an ESD protected environment.

References

1. SFF-8436 QSFP+
2. Ethernet 100GBASE-LR4
3. OTN OTU4

Ordering information

Part Number	Product Description
QQS-SPO111-LR4CA	QSFP28, 100GBASE-LR4 and OTU4, LAN_WDM 10km

Important Notice

Performance figures, data and any illustrative material provided in this data sheet are typical and must be specifically confirmed in writing by GIGALIGHT before they become applicable to any particular order or contract. In accordance with the GIGALIGHT policy of continuous improvement specifications may change without notice.

The publication of information in this data sheet does not imply freedom from patent or other protective rights of GIGALIGHT or others. Further details are available from any GIGALIGHT sales representative.

sales@gigalight.com

<https://www.gigalight.com/>

Revision History

Revision	Date	Description
V0	14-Jun-2017	Advance Release.
V1	20-Apr-2021	Modify Regulatory Compliance