

## 12Gbps Video SFP Optical Receiver, 20km Reach GHR-12G-L2CDM

### Features

- ✓ SD/HD/3G/6G/12G-SDI SFPReceiver
- ✓ ST 259, ST 292-1,ST 424, ST-2081 and ST-2082 compatible
- ✓ Metal enclosure for Lower EMI
- ✓ Supports video pathological patterns for SD-SDI, HD-SDI,
- ✓ 3G-SDI,6G-SDI and 12G SDI
- ✓ With reclocker in the module
- ✓ Compliant with SFP MSA
- ✓ ROHS compliant(lead free)
- ✓ single 3.3V power supply
- ✓ Hot-pluggable SFP footprint
- ✓ Operating case temperature range: 0 to +70°C



### Applications

- ✓ Serial Digital Fiber Transmission System for SMPTE ST 259, SMPTE ST 344, SMPTE ST 292-1/2, SMPTE ST 424, SMPTE ST 2081-1 and SMPTE ST 2082-1 Signals
- ✓ UHDTV/HDTV/SDTV Service Interfaces

### Description

Gigalight's Video Receiver is designed to receive data rates from 50Mbps to 11.88Gbps, compliant with SMPTE ST 2082-1 (12G UHD-SDI), ST 2081-1 (6G UHD-SDI), ST424 (3G SDI), ST 292-1 (HD-SDI), and ST 259 (SD-SDI). Gigalight's Video Receiver supports SDI pathological patterns signals.

The Receiver includes these sections: a PIN photodiode integrated with a trans-impedance preamplifier (TIA), Reclocker, and a MCU controller. They are Complianted with SFP MSA

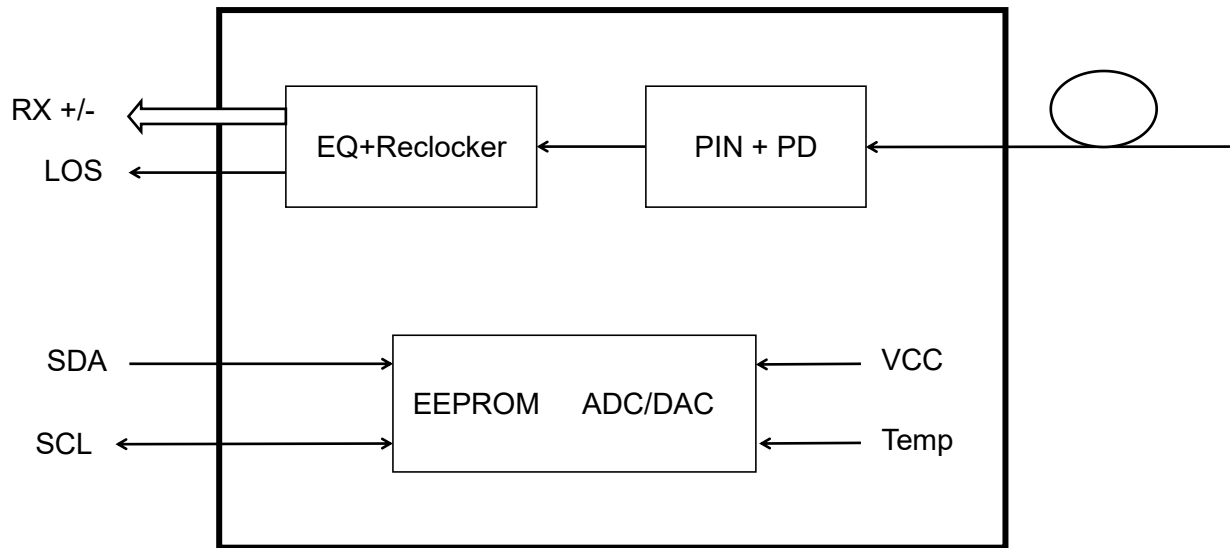

**Figure 1. Module Block Diagram**

### Absolute Maximum Ratings

Parameter	Symbol	Min	Max	Unit
Supply Voltage	V <sub>cc</sub>	-0.5	5.25	V
Storage Temperature	T <sub>s</sub>	-40	+85	°C
Operating Humidity	-	5	85	%

### Recommended Operating Conditions

Parameter	Symbol	Min	Typical	Max	Unit
Operating Case Temperature	T <sub>c</sub>	0		+70	°C
Power Supply Voltage	V <sub>cc</sub>	3.13	3.3	3.47	V
Power Supply Current	I <sub>cc</sub>		150		mA
Data Rate			12		Gbps

### Optical and Electrical Characteristics

Parameter	Symbol	Min	Typical	Max	Unit	Notes
Center Wavelength	λ <sub>c</sub>	1260		1580	nm	
Receiver Sensitivity@ 11.88Gbps				-11	dBm	1
Receiver Sensitivity@ 5.94Gbps				-13	dBm	
Receiver Sensitivity@ 2.97Gbps				-15	dBm	
Receiver Overload		1			dBm	2
LOS De-Assert	LOS <sub>D</sub>			-18	dBm	
LOS Assert	LOS <sub>A</sub>	-28			dBm	
LOS Hysteresis	LOS <sub>H</sub>	1		4	dB	
Data Output Swing Differential	V <sub>out</sub>	400	800	800	mV	3
LOS	High	2.0		V <sub>cc</sub>	V	

	Low			0.8	V	
--	-----	--	--	-----	---	--

**Note:**

1. Measured With Pathological Patterns 11.88Gpbs (4096\*2160 P60,100% Bars);5.94Gpbs (4096\*2160 P29.97,100% Bars);2.97Gpbs (2048\*1080 P50,100% Bars).
2. Internally AC-coupled, minimum input overload power for SMPTE ST 2081-1, SMPTE ST 2082-1.
3. Rise and fall times, 20% to 80%,

**Timing and Electrical**

Parameter	Symbol	Min	Typical	Max	Unit
Time To Initialize	t_init			300	ms
Serial ID Clock Rate	f_serial_clock		100		KHz
MOD_DEF (0:2)-High	V <sub>H</sub>	2		V <sub>cc</sub>	V
MOD_DEF (0:2)-Low	V <sub>L</sub>			0.8	V

**Diagnostics Specification**

Parameter	Range	Unit	Accuracy	Calibration
temperature	0 to +70	°C	±3°C	Internal / External
Voltage	3.0 to 3.6	V	±3%	Internal / External
RX Power	-24to +1	dBm	±3dB	Internal / External

**I2C Bus Interface**

The I2C bus interface uses the 2-wire serial CMOS E2PROM protocol. The serial interface meets the following specifications:

- 1.Support a maximum clock rate of 280Khz.
2. Input/Output levels comply with LVCMOS/LVTTL or compatible logics.

Low: 0 – 0.8 V

High: 2.0 – 3.3 V

Undefined: 0.8 – 2.0 V

**Pin Description**

Pin	Signal Name	Description	Plug Seq.	Notes
1	VEE	Ground	1	
2	VEE	Ground	3	
3	NC	Not Connected	3	
4	MOD_DEF(2)-SDA	2-wire Serial Interface Data Line	3	Note 1
5	MOD_DEF(1)-SCL	2-wire Serial Interface Clock	3	Note 1
6	MOD_DEF(0)-PRESENCE (VEE)	TTL Low	3	Note 1
7	Rate (NC)	Not Connected	3	
8	LOS	Loss of Signal	3	Note 2

9	VEE	Ground	3	
10	VEE	Ground	1	
11	VEE	Ground	1	
12	RX-	Receiver Inverted Data Output	3	Note 3
13	RX+	Receiver Non-Inverted Data Output	3	Note 3
14	VEE	Ground	1	
15	VCC	Receiver Power Supply	2	
16	VCC	Receiver Power Supply	2	
17	VEE	Ground	1	
18	NC	Not Connected	3	
19	NC	Not Connected	3	
20	VEE	Ground	1	

### Note:

Plug Seq.: Pin engagement sequence during hot plugging.

1.Mod-Def 0,1,2. These are the module definition pins. They should be pulled up with a 4.7k~10kΩ resistor on the host board. The pull-up voltage shall be VccT or VccR.

Mod-Def 0 is grounded by the module to indicate that the module is present.

Mod-Def 1 is the clock line of two wire serial interface for serial ID.

Mod-Def 2 is the data line of two wire serial interface for serial ID.

2.LOS is an open collector output, which should be pulled up with a 4.7k~10kΩ resistor on the host. Pull up voltage between 2.0V and Vcc+0.3V. Logic 1 indicates loss of signal; Logic 0 indicates normal operation. In the low state, the output will be pulled to less than 0.8V.

3.RX-/+: These are the differential receiver outputs. They are internally AC-coupled 100 differential lines which should be terminated with 100Ω (differential) on the host.

### Pin Definition

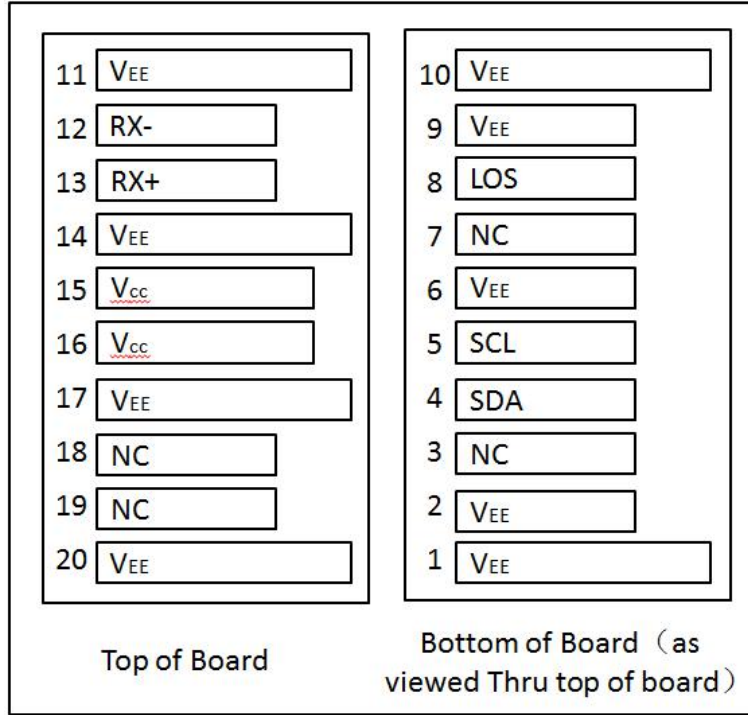

**Figure 2. Electrical Pin-out Details**

**Mechanical Dimensions**

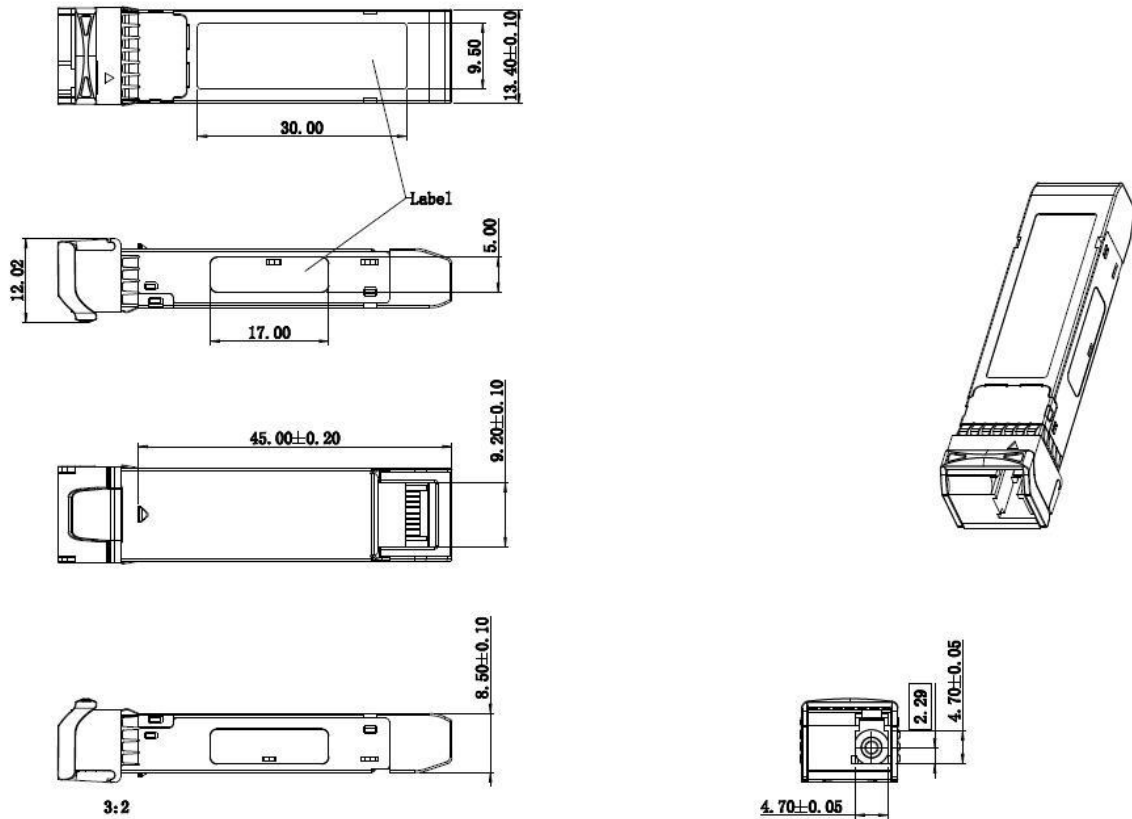

**Figure 3. Mechanical Specifications**

**Regulatory Compliance**

Feature	Standard
Environmental protection	2011/65/EU
CE EMC	EN55032: 2015 EN55035: 2017 EN61000-3-2:2014 EN61000-3-3:2013
FCC	FCC Part 15, Subpart B; ANSI C63.4-2014
Product Safety	EN/UL 60950-1, 2nd Edition, 2014-10-14

**⚠ CAUTION:**

Use of controls or adjustment or performance of procedures other than those specified herein may result in hazardous radiation exposure.

**Ordering Information**

Part Number	Product Description
GHR-12G-L2CDM	SD/HD/3G/6G/12G SDI Receiver, MSA , Reclocker

**Important Notice**

Performance figures,data and any illustrative material provided in this data sheet are typical and must be specifically confirmed in writing by Gigalight before they become applicable to any particular order or contract. In accordance with the Gigalight policy of continuous improvement specifications may change without notice.

The publication of information in this data sheet does not imply freedom from patent or other protective rights of Gigalight or others. Further details are available from any Gigalight sales representative.

E-mail: [sales@gigalight.com](mailto:sales@gigalight.com)  
Official Site: [www.gigalight.com](http://www.gigalight.com)

**Revision History**

Revision	Date	Description
V0	Mar-14- 2019	Advance Release.
V1	Oct-14-2019	Modified current standards.