

Gigalight 200GE QSFP56 Direct Attach Cable

P/N: GQS-PC201-XXC

Features

- ◆ QSFP56 conforms to the Small Form Factor SFF8636
- ◆ 4-Channel Full-Duplex Passive Copper Cable Transceiver
- ◆ Support data rates : 56Gb/s (Support 28GBaud PAM4)
- ◆ Maximum aggregate data rate: 200Gb/s (4 x 50Gb/s)
- ◆ Power Supply :+3.3V
- ◆ Low crosstalk
- ◆ I²C based two-wire serial interface for EEPROM signature which can be customized
- ◆ Operating Temperature: 0~ 70 °C
- ◆ ROHS Compliant

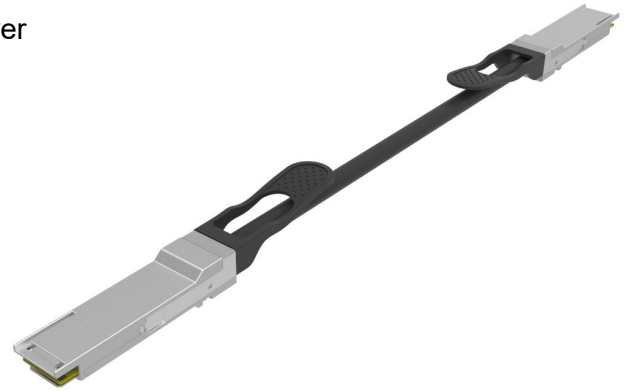

Applications

- ◆ 40GE/100GE/200GE
- ◆ Infiniband QDR/FDR/EDR/HDR
- ◆ Data storage and communication industry
- ◆ Switch / router / HBA
- ◆ Enterprise network
- ◆ SAN
- ◆ Data Center Network

STANDARDS COMPLIANCE

- ◆ IEEE 802.3bj&IEEE802.3cd
- ◆ 100GEBASE-CR4&200GBASE-CR4
- ◆ InfiniBand architecture
- ◆ QSFP28 MSA
- ◆ RoHS Compliant

Product Description

The 200GE QSFP56 cable assemblies are high performance, cost effective I/O solutions for LAN, HPC and SAN. The high speed cable assemblies meet and exceed 200 Gigabit Ethernet, InfiniBand EDR /HDR and temperature requirements for performance and reliability. The cables are compliant with SFF-8436 specifications and provide connectivity between devices using QSFP ports.

Recommended Operating Conditions

Parameter	Symbol	Min	Typical	Max	Unit
Storage Ambient Temperature		-40		+85	°C
Operating Case Temperature	Tc	0		+70	°C
Power Supply Voltage	V _{CC3}	3.14	3.3	3.47	V
Data Rate Per Lane		1		28	GBaud/s

Differential Impedance

Parameter	Symbol	Min	Typical	Max	Unit
Differential Impedance(bulk cable)	Rin1,P-P	95	100	110	Ω
Differential Impedance (Mated connector)	Rin2,P-P	90	100	110	Ω
Differential Impedance(cable termination)	Rin3,P-P	85	100	110	Ω

PCB Contact Configuration

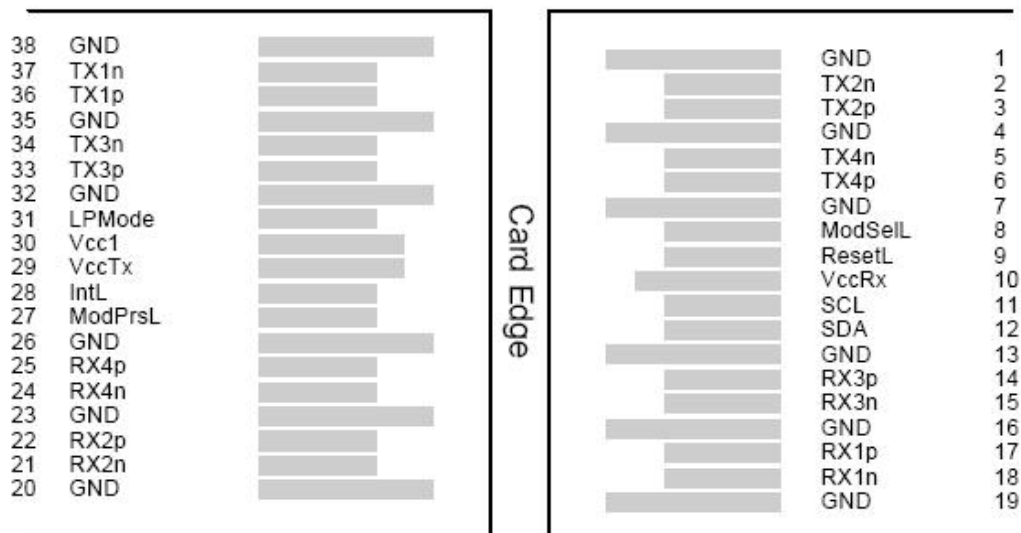

ELECTRICAL

Item	Specification
Low Level Contact Resistance	Initial: Baseline, with 75mm cable from the backshell edge. Change : 20 milliohms maximum
Insulation Resistance (Raw cable)	100VDC, 1000Mohm (Min.)
Dielectric Withstanding Voltage	AC 300V 1min, no breakdown or flash

SIGNAL INTEGRITY

A	Time domain parameter	Test condition	SPEC		Equipment
1	Differential Impedance(bulk cable)	TDR Tr:25ps	100+10/-5ohms		E5071C or DSA8300
2	Differential Impedance (Mated connector)		100+10/-10ohms		
3	Differential Impedance(cable termination)		100+10/-15ohms		
4	Intra-skew		L*15+20	L:length(m) SPEC:ps	
B	Frequency domain parameter	Test condition	Test spec(dB)	f(GHz)	
1	SDD11/SD D22	Freq:50MHz ~20GHz Points:1601	-22+20/25.78*f*10 ⁽⁻³⁾ -10.66+14*log((f*10 ⁽⁻³⁾)/5.5) ≤5.3dB@13.26GHz	0.05≤f<4.1 4.1≤f≤19	E5071C
2	SCC11/SC C22	Freq:50MHz ~20GHz Points:1601	≤-2dB	0.2≤f≤19	
3	SDC11/SD C22	Freq:50MHz ~20GHz Points:1601	-16+2*f/3	0.05≤f≤2	
4	SCD21-SDD21	Freq:50MHz ~20GHz Points:1601	10 as 0.01≤f < 12.89 -27+29/22*f*0.001 as 12.89≤f < 15.7 6.3 as 15.7≤f≤19	0.01≤f≤19	
5	MDNEXT	Freq:50MHz ~20GHz Points:1601	≤-26dB@12.89GHz	0.01≤f≤19	

6	SDD21	Freq:50MHz ~20GHz Points:1601 IF: 1KHz	$-0.7*(f*10^{(-3)})^{0.5-0.3}$ $*(f*10^{(-3)})-$ $0.01*(f*10^{(-3)})^2$ $<17.16dB@13.26GHz$	$0.01 \leq f \leq 19$
7	COM	IEEE802.3cd	>3dB	

MECHANICAL

Item	Specification
Mating Force	40N Max. With retention latch disengaged.
Un-mating Force	30N Max. With retention latch disengaged.
Latch retention force	90N Min.
Durability	250 cycles

Mechanical Dimensions

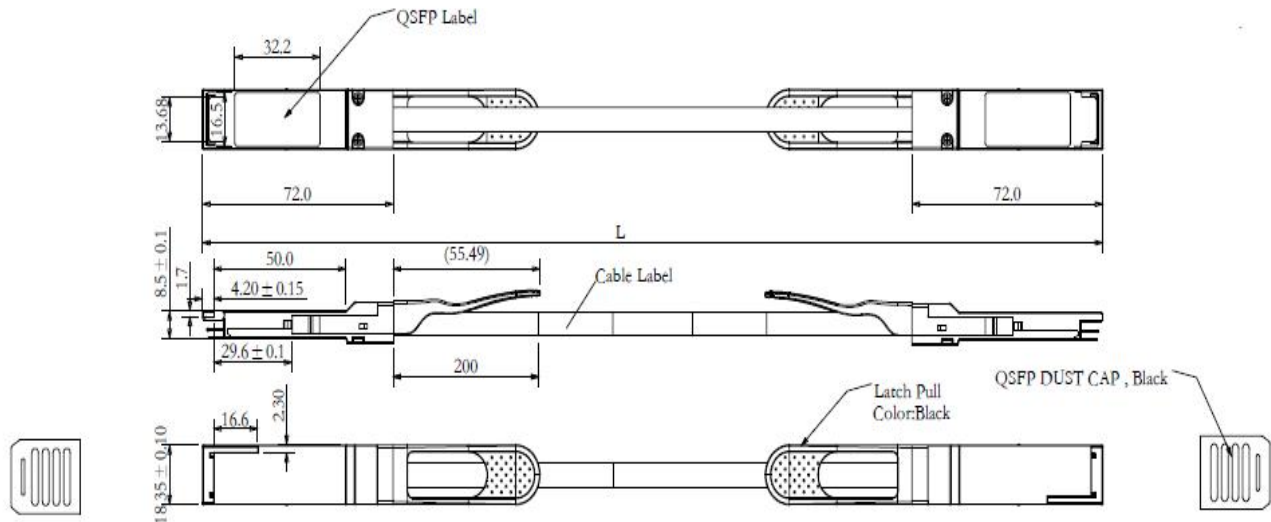

ENVIRONMENTAL

Item	Specification
Physical shock	Subject mated specimens to 30G's half-sine shock pulses of 11 milliseconds duration. 3 shocks in each direction applied along 3 mutually perpendicular planes, 18 total shocks
Vibration (random)	Subject mated specimens to 3.10G's rms between 20-500 Hz for 15 minutes in each of 3 mutually perpendicular planes
Thermal shock	100 cycles of: a) -55°C for 30 minutes b) +85°C for 30 minutes
Temperature Life	Subject mated Specimens to +105°C for 500 hours
Humidity and Temperature cycling	Subject unmated specimens to 10 cycles (10 days) between 25 and 65°C at 80% to 100% RH
Visual Examination.	Connectors & contacts shall have no evidence of physical defects or otherwise unfit for testing.

Regulatory Compliance

Gigalight GQS-PC201-XXC passive cable assemblies meet the requirements of the following standards:

Feature	Standard
Electrical Safety	EN 62368-1: 2014 IEC 62368-1:2014 UL 62368-1:2014
Environmental protection	Directive 2011/65/EU with amendment(EU)2015/863
CE EMC	EN55032: 2015 EN55035: 2017 EN61000-3-2:2014 EN61000-3-3:2013
FCC	FCC Part 15, Subpart B; ANSI C63.4-2014

Ordering information

Part Number	GQS-PC201-XXC		
Length (meter)	1	2	3
Wire gauge (AWG)	30	30	26

Example:

GQS-PC201-01C/30AWG

GQS-PC201-03C/26AWG

Important Notice

Performance figures, data and any illustrative material provided in this data sheet are typical and must be specifically confirmed in writing by GIGALIGHT before they become applicable to any particular order or contract. In accordance with the GIGALIGHT policy of continuous improvement specifications may change without notice.

The publication of information in this data sheet does not imply freedom from patent or other protective rights of GIGALIGHT or others. Further details are available from any GIGALIGHT sales representative.

sales@gigalight.com.cn

<http://www.gigalight.com>

Revision History

Version	Date	Description
V0	May 13th, 2021	New release
V1	Apr. 2nd, 2022	Update differential impedance information