

## 40Gb/s QSFP+ Parallel Single Mode (PSM) Module 10km GQM-SPO400-LR4CA

### Features

- ◆ Full duplex 4 channel 1310nm parallel module
- ◆ SFF-8436 QSFP+ compliant
- ◆ Hot pluggable electrical interface
- ◆ Differential AC-coupled high speed data interface
- ◆ 4 channels 1310nm DFB laser
- ◆ 4 channels PIN photo detector array
- ◆ Maximum link length of 10km on G652
- ◆ Single male MPO(APC 8-degree) connector receptacle
- ◆ Maximum power consumption 2.5W
- ◆ Housing isolated from connector ground
- ◆ Operating case temperature 0°C to +70°C
- ◆ 3.3V power supply voltage
- ◆ RoHS 6 compliant



### Applications

- ◆ Infiniband Connectivity SDR/DDR/QDR
- ◆ OC-192 ,OTU1e ,OTU2 ,OTU2e and OTU3
- ◆ 10/40 Gigabit Ethernet
- ◆ 2/4/8 Gbps Fiber Channel
- ◆ Data Centers and Storage Arrays

### Description

QSFP PSM LR4 are a high performance, low power consumption, long reach interconnect solution supporting 40G Ethernet, fiber channel and PCIe. It is compliant with the QSFP MSA and 40GbE PSM4. QSFP PSM LR4 is an assembly of 4 full-duplex lanes, where each lane is capable of transmitting data at rates up to 11.0957Gb/s, providing an aggregated rate of 40Gb/s.

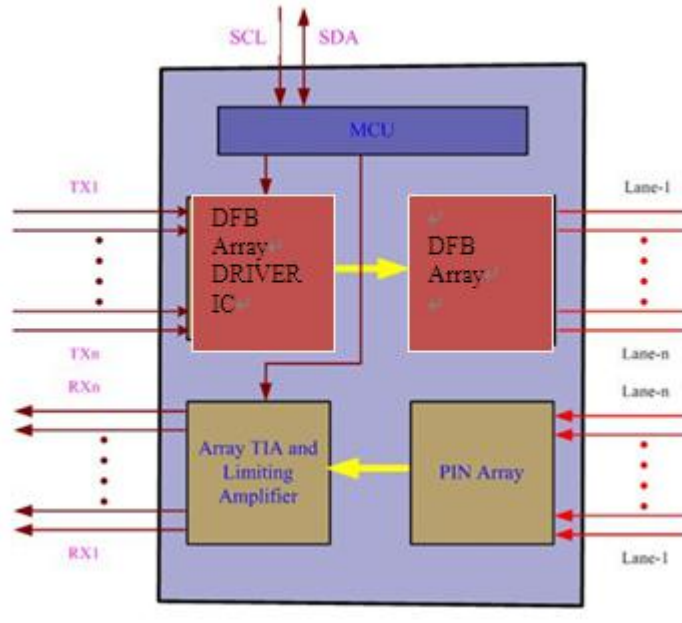

**Figure1. Module Block Diagram**

QSFP PSM LR4 is one kind of parallel transceiver. DFB and PIN array package is key technique, through I2C system can contact with module.

### Absolute Maximum Ratings

Parameter	Symbol	Min	Max	Unit
Supply Voltage	Vcc	-0.3	3.6	V
Input Voltage	Vin	-0.3	Vcc+0.3	V
Storage Temperature	Tst	-20	85	°C
Case Operating Temperature	Top	0	70	°C
Humidity(non-condensing)	Rh	5	95	%

### Recommended Operating Conditions

Parameter	Symbol	Min	Typical	Max	Unit
Supply Voltage	Vcc	3.13	3.3	3.47	V
Operating Case temperature	Tca	0		70	°C
Data Rate Per Lane	fd	9.953		11.095	Gbps
Humidity	Rh	5		85	%
Power Dissipation	Pm			3.5	W
Link Distance with G652	Rb	D		10	km

### Specifications

Parameter	Symbol	Min	Typical	Max	Unit
Differential input impedance	Zin	90	100	110	ohm
Differential Output impedance	Zout	90	100	110	ohm
Differential input voltage amplitude	$\Delta V_{in}$	350		1200	mVp-p
Differential output voltage amplitude	$\Delta V_{out}$	425		1600	mVp-p
Skew	Sw			300	ps
Bit Error Rate	BR			E-12	
Input Logic Level High	V <sub>IH</sub>	2.0		V <sub>CC</sub>	V
Input Logic Level Low	V <sub>IL</sub>	0		0.8	V
Output Logic Level High	V <sub>OH</sub>	V <sub>CC</sub> -0.5		V <sub>CC</sub>	V
Output Logic Level Low	V <sub>OL</sub>	0		0.4	V

**Note:**

1. BER=10<sup>-12</sup>; PRBS 2<sup>31</sup>-1.
2. Differential input voltage amplitude is compliant with the IEEE802.3 Annex 86A and SFF8436, and it is measured at TP1 .
3. Differential output voltage amplitude is compliant with the IEEE802.3 Annex 86A and SFF8436, and it is measured at TP4 .

**Optical Characteristics**

Parameter	Symbol	Min	Typical	Max	Unit	Notes	
<b>Transmitter</b>							
Centre Wavelength	$\lambda_c$	1290	1310	1330	nm	-	
SMSR	$\sigma$	30	-		dB	-	
Transmit OMA per Lane	T <sub>xOMA</sub>	-4		3.5	dBm		
Average launch power, each lane	P <sub>out</sub>	-6	-	-1	dBm	-	
Difference in launch power between any two lanes (OMA)	P <sub>tx,diff</sub>			6.5	dB	-	
Extinction Ratio	ER	6	-	-	dB	-	
Transmitter and dispersion penalty (TDP), each lane	TDP			2.6	dB	-	
Average launch power of OFF transmitter, each lane	P <sub>off</sub>			-30	dBm	-	
Optical Return Loss Tolerance (max)	R <sub>L<sub>T</sub></sub>			12	dB		
Transmitter Reflectance	R <sub>T</sub>			-12	dB		
Eye Mask coordinates: X1, X2, X3, Y1, Y2, Y3		SPECIFICATION VALUES 0.25, 0.4, 0.45, 0.25, 0.28, 0.4					Hit Ratio = 5x10 <sup>-5</sup>
<b>Receiver</b>							
Centre Wavelength	$\lambda_c$	1290	1310	1330	nm	-	

Stressed receiver sensitivity in OMA, each lane	SEN			-10.3	dBm	1
Receiver sensitivity in OMA, each lane (PRBS 2 <sup>31</sup> -1 and BER=10 <sup>-12</sup> )				-12.6	dBm	2
Maximum Average power at receiver input, each lane				0.5	dBm	-
Difference in Receive Power between any Two Lanes (OMA)	Prx,diff			7.5	dB	
Receiver Reflectance	R <sub>R</sub>			-26	dB	-
LOS Assert	LOSA	-30			dBm	-
LOS De-Assert	LOSD			-14	dBm	-
LOS Hysteresis	LOSH	0.5			dB	-

**Note:**

1. Measured with conformance test signal at TP3 for BER = 10e-12
2. 10GBASE-LR spec .

**Pin Descriptions**

Pin	Logic	Symbol	Name/Description	Ref.
1		GND	Module Ground	1
2	CML-I	Tx2-	Transmitter inverted data input	
3	CML-I	Tx2+	Transmitter non-inverted data input	
4		GND	Module Ground	1
5	CML-I	Tx4-	Transmitter inverted data input	
6	CML-I	Tx4+	Transmitter non-inverted data input	
7		GND	Module Ground	1
8	LVTTL-I	MODSEIL	Module Select	2
9	LVTTL-I	ResetL	Module Reset	2
10		VCCR <sub>x</sub>	+3.3v Receiver Power Supply	
11	LVC MOS-I	SCL	2-wire Serial interface clock	2
12	LVC MOS-I/O	SDA	2-wire Serial interface data	2
13		GND	Module Ground	1
14	CML-O	RX3+	Receiver non-inverted data output	
15	CML-O	RX3-	Receiver inverted data output	
16		GND	Module Ground	1
17	CML-O	RX1+	Receiver non-inverted data output	
18	CML-O	RX1-	Receiver inverted data output	
19		GND	Module Ground	1
20		GND	Module Ground	1
21	CML-O	RX2-	Receiver inverted data output	

22	CML-O	RX2+	Receiver non-inverted data output	
23		GND	Module Ground	1
24	CML-O	RX4-	Receiver inverted data output	
25	CML-O	RX4+	Receiver non-inverted data output	
26		GND	Module Ground	1
27	LVTTL-O	ModPrsL	Module Present, internal pulled down to GND	
28	LVTTL-O	IntL	Interrupt output, should be pulled up on host board	2
29		VCCTx	+3.3v Transmitter Power Supply	
30		VCC1	+3.3v Power Supply	
31	LVTTL-I	LPMODE	Low Power Mode	2
32		GND	Module Ground	1
33	CML-I	Tx3+	Transmitter non-inverted data input	
34	CML-I	Tx3-	Transmitter inverted data input	
35		GND	Module Ground	1
36	CML-I	Tx1+	Transmitter non-inverted data input	
37	CML-I	Tx1-	Transmitter inverted data input	
38		GND	Module Ground	1

**Notes:**

1. Module circuit ground is isolated from module chassis ground within the module.
2. Open collector; should be pulled up with 4.7k – 10k ohms on host board to a voltage between 3.15V and 3.6V.

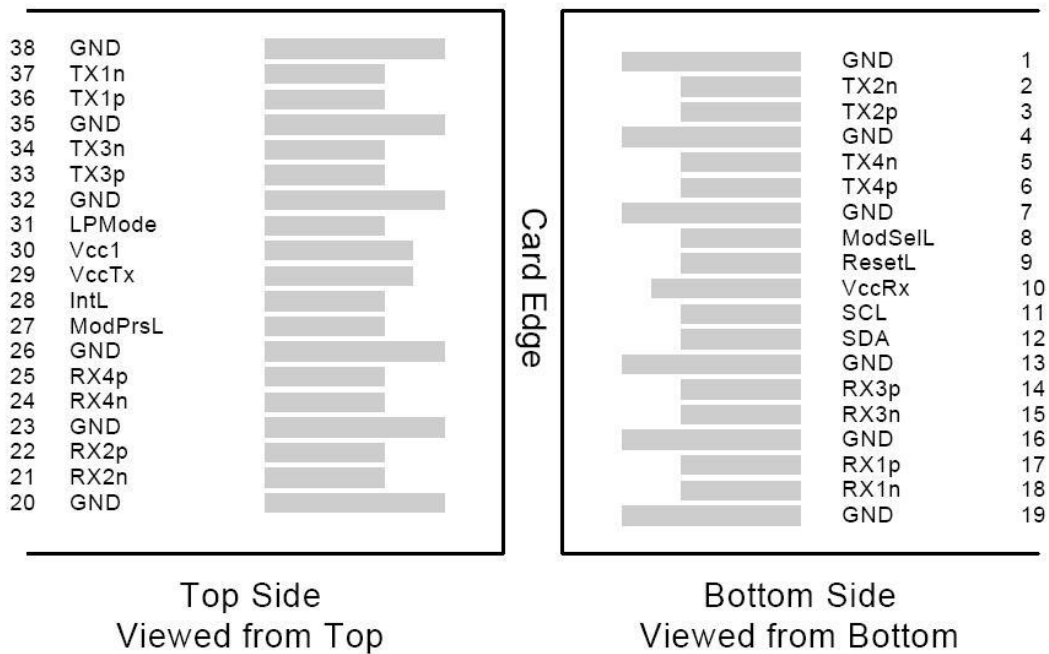

**Figure2. Electrical Pin-out Details**

**ModSelL Pin**

The ModSelL is an input pin. When held low by the host, the module responds to 2-wire serial

communication commands. The ModSelL allows the use of multiple QSFP modules on a single 2-wire interface bus. When the ModSelL is “High”, the module will not respond to any 2-wire interface communication from the host.

ModSelL has an internal pull-up in the module.

#### **ResetL Pin**

ResetL pin has an internal pull-up in the module. A low level on the ResetL pin for longer than the minimum pulse length ( $t_{\text{Reset\_init}}$ ) initiates a complete module reset, returning all user module settings to their default state. Module Reset Assert Time ( $t_{\text{init}}$ ) starts on the rising edge after the low level on the ResetL pin is released. During the execution of a reset ( $t_{\text{init}}$ ) the host shall disregard all status bits until the module indicates a completion of the reset interrupt. The module indicates this by posting an IntL signal with the Data\_Not\_Ready bit negated. Note that on power up (including hot insertion) the module will post this completion of reset interrupt without requiring a reset.

#### **LPMode Pin**

Gigalight QSFP PSM LR4 operate in the low power mode (less than 1.5 W power consumption)

This pin active high will decrease power consumption to less than 1W.

#### **ModPrsL Pin**

ModPrsL is pulled up to Vcc on the host board and grounded in the module. The ModPrsL is asserted “Low” when the module is inserted and deasserted “High” when the module is physically absent from the host connector.

#### **IntL Pin**

IntL is an output pin. When “Low”, it indicates a possible module operational fault or a status critical to the host system. The host identifies the source of the interrupt by using the 2-wire serial interface. The IntL pin is an open collector output and must be pulled up to Vcc on the host board.

## **Power Supply Filtering**

The host board should use the power supply filtering shown in Figure3.

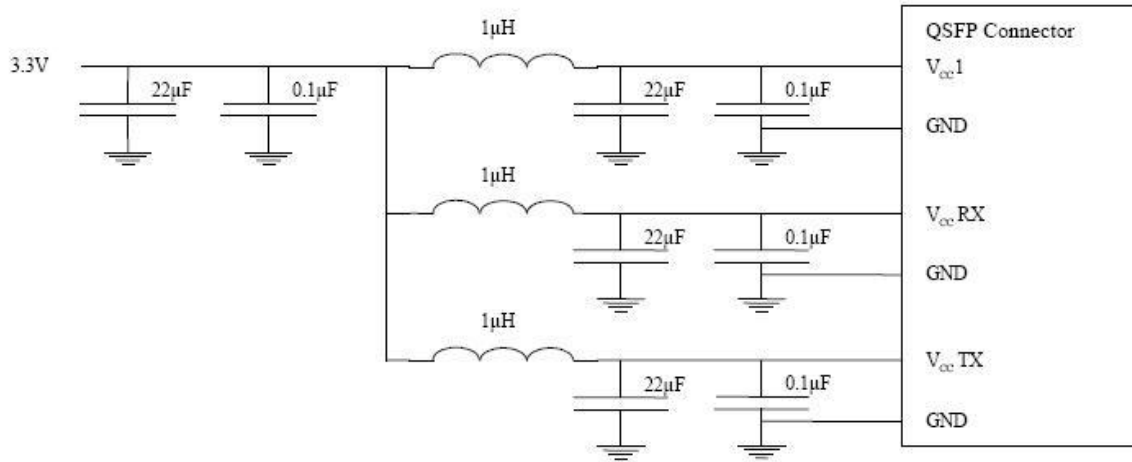
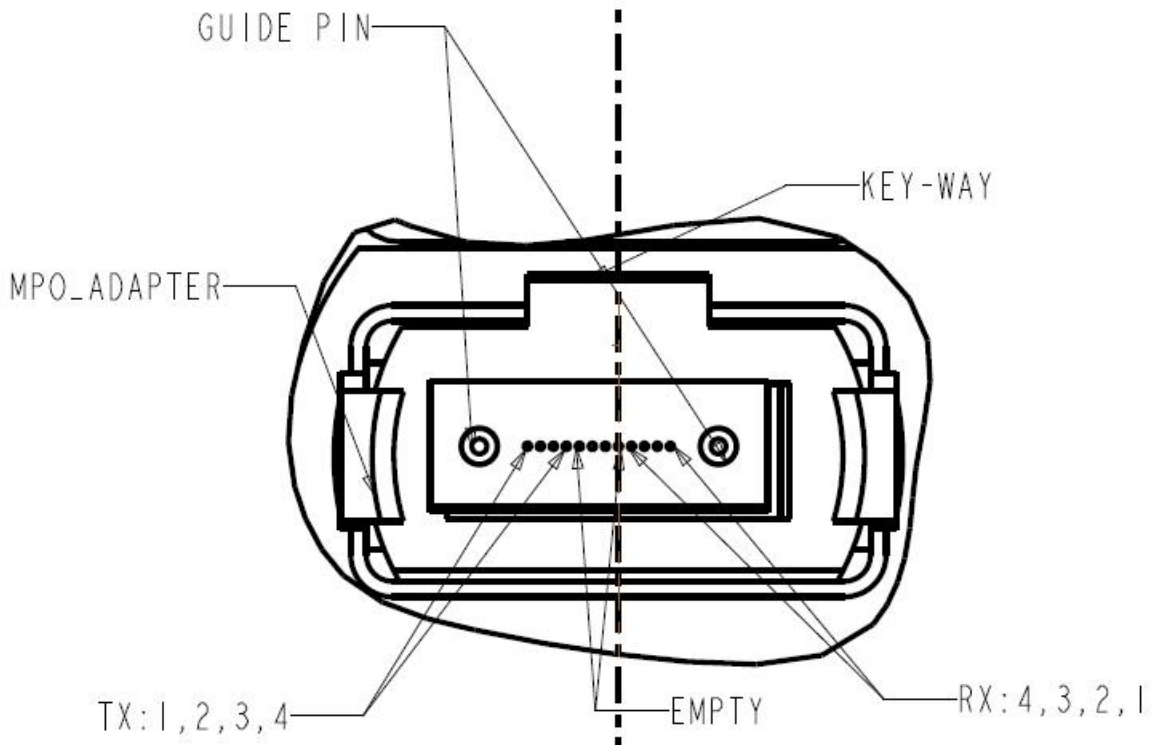

Figure3. Host Board Power Supply Filtering

40G QSFP+ PSM LR4 10km Optical Interface



DIAGNOSTIC MONITORING INTERFACE(OPTIONAL)

Digital diagnostics monitoring function is available on all Gigalight QSFP PSM AOCs. A 2-wire serial interface provides user to contact with module.

The structure of the memory is shown in Figure 4. The memory space is arranged into a lower, single page, address space of 128 bytes and multiple upper address space pages. This structure permits timely access to addresses in the lower page, such as Interrupt Flags and Monitors. Less time critical time entries, such as serial ID information and threshold settings, are available with the Page Select function.

The interface address used is A0xh and is mainly used for time critical data like interrupt handling in order to enable a one-time-read for all data related to an interrupt situation. After an interrupt, IntL, has been asserted, the host can read out the flag field to determine the affected channel and type of flag.

2-wire serial address, 1010000x (A0h)"

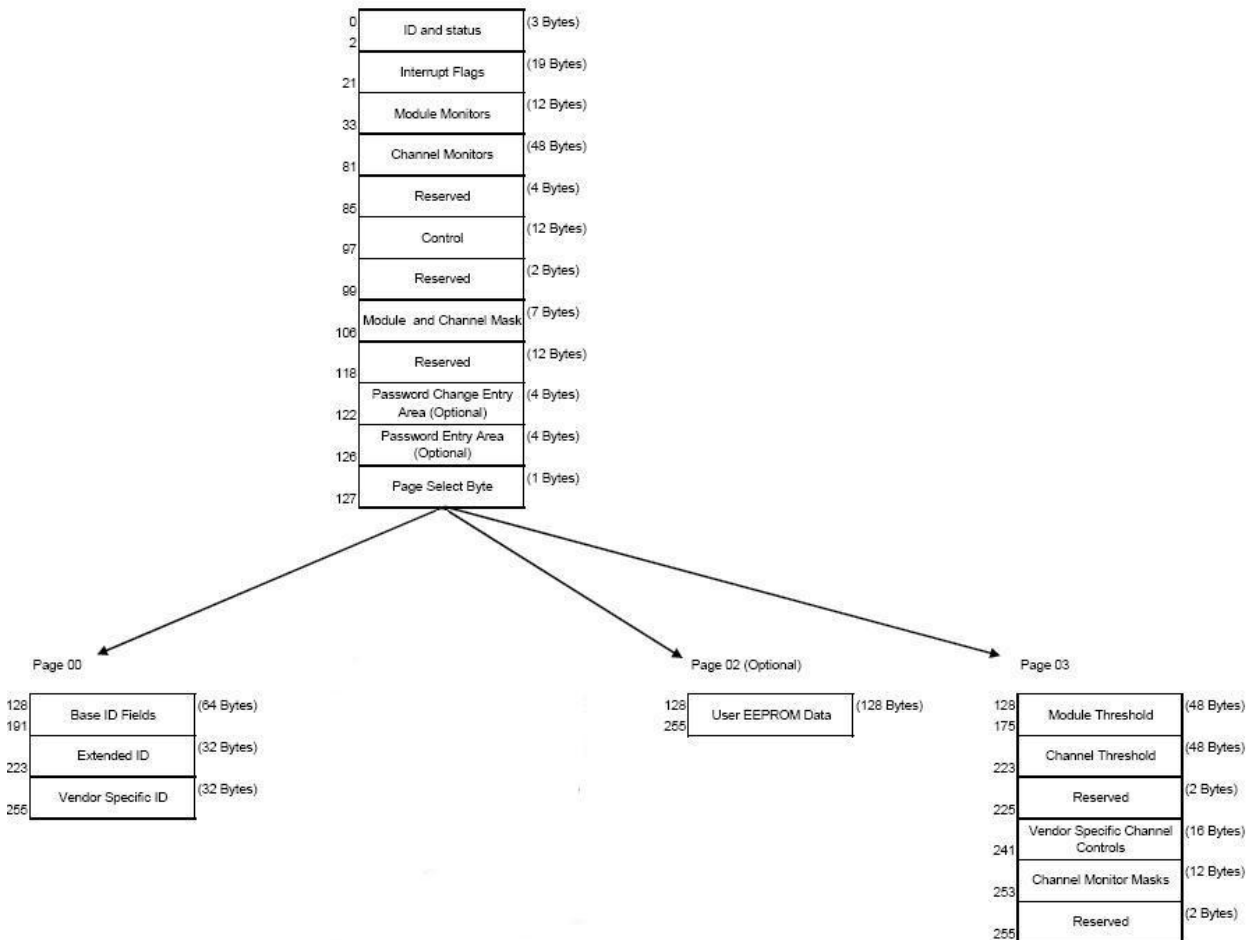

**Figure4. QSFP Memory Map**



Byte Address	Description	Type
0	Identifier (1 Byte)	Read Only
1-2	Status (2 Bytes)	Read Only
3-21	Interrupt Flags (31 Bytes)	Read Only
22-33	Module Monitors (12 Bytes)	Read Only
34-81	Channel Monitors (48 Bytes)	Read Only
82-85	Reserved (4 Bytes)	Read Only
86-97	Control (12 Bytes)	Read/Write
98-99	Reserved (2 Bytes)	Read/Write
100-106	Module and Channel Masks (7 Bytes)	Read/Write
107-118	Reserved (12 Bytes)	Read/Write
119-122	Reserved (4 Bytes)	Read/Write
123-126	Reserved (4 Bytes)	Read/Write
127	Page Select Byte	Read/Write

**Figure5. Low Memory Map**

Byte Address	Description	Type
128-175	Module Thresholds (48 Bytes)	Read Only
176-223	Reserved (48 Bytes)	Read Only
224-225	Reserved (2 Bytes)	Read Only
226-239	Reserved (14 Bytes)	Read/Write
240-241	Channel Controls (2 Bytes)	Read/Write
242-253	Reserved (12 Bytes)	Read/Write
254-255	Reserved (2 Bytes)	Read/Write

**Figure6. Page 03 Memory Map**

Address	Name	Description
128	Identifier (1 Byte)	Identifier Type of serial transceiver
129	Ext. Identifier (1 Byte)	Extended identifier of serial transceiver
130	Connector (1 Byte)	Code for connector type
131-138	Transceiver (8 Bytes)	Code for electronic compatibility or optical compatibility
139	Encoding (1 Byte)	Code for serial encoding algorithm
140	BR, nominal (1 Byte)	Nominal bit rate, units of 100 Mbits/s
141	Extended RateSelect Compliance (1 Byte)	Tags for Extended RateSelect compliance
142	Length SMF (1 Byte)	Link length supported for SM fiber in km
143	Length E-50 $\mu\text{m}$ (1 Byte)	Link length supported for EBW 50/125 $\mu\text{m}$ fiber, units of 2 m
144	Length 50 $\mu\text{m}$ (1 Byte)	Link length supported for 50/125 $\mu\text{m}$ fiber, units of 1 m
145	Length 62.5 $\mu\text{m}$ (1 Byte)	Link length supported for 62.5/125 $\mu\text{m}$ fiber, units of 1 m
146	Length copper (1 Byte)	Link length supported for copper, units of 1 m
147	Device Tech (1 Byte)	Device technology
148-163	Vendor name (16 Bytes)	QSFP vendor name (ASCII)
164	Extended Transceiver (1 Byte)	Extended Transceiver Codes for InfiniBand <sup>†</sup>
165-167	Vendor OUI (3 Bytes)	QSFP vendor IEEE vendor company ID
168-183	Vendor PN (16 Bytes)	Part number provided by QSFP vendor (ASCII)
184-185	Vendor rev (2 Bytes)	Revision level for part number provided by vendor (ASCII)
186-187	Wavelength (2 Bytes)	Nominal laser wavelength (Wavelength = value / 20 in nm)
188-189	Wavelength Tolerance (2 Bytes)	Guaranteed range of laser wavelength (+/- value) from Nominal wavelength (Wavelength Tol. = value / 200 in nm)
190	Max Case Temp (1 Byte)	Maximum Case Temperature in Degrees C
191	CC_BASE (1 Byte)	Check code for Base ID fields (addresses 128-190)
192-195	Options (4 Bytes)	Rate Select, TX Disable, TX Fault, LOS
196-211	Vendor SN (16 Bytes)	Serial number provided by vendor (ASCII)
212-219	Date code (8 Bytes)	Vendor's manufacturing date code
220	Diagnostic Monitoring Type (1 Byte)	Indicates which type of diagnostic monitoring is implemented
221	Enhanced Options (1 Byte)	Indicates which optional enhanced features are implemented
222	Reserved (1 Byte)	Reserved
223	CC_EXT	Check code for the Extended ID Fields (addresses 192-222)
224-255	Vendor Specific (32 Bytes)	Vendor Specific EEPROM

**Figure7. Page 00 Memory Map**

Page02 is User EEPROM and its format decided by user.

The detail description of low memory and page00.page03 upper memory please see

SFF-8436 document.

## Timing for Soft Control and Status Functions

Parameter	Symbol	Max	Unit	Conditions
Initialization Time	t_init	2000	ms	Time from power on <sup>2</sup> , hot plug or rising edge of Reset until the module is fully functional <sup>3</sup> This time does not apply to non-Power Level 0 modules in the Low Power State
Reset Init Assert Time	t_reset_init	2	μs	A Reset is generated by a low level longer than the minimum reset pulse time present on the ResetL pin.
Serial Bus Hardware Ready Time	t_serial	2000	ms	Time from power on <sup>2</sup> until module responds to data transmission over the 2-wire serial bus
Monitor Data Ready Time	t_data	2000	ms	Time from power on <sup>2</sup> to data not ready, bit 0 of Byte 2, deasserted and IntL asserted
Reset Assert Time	t_reset	2000	ms	Time from rising edge on the ResetL pin until the module is fully functional <sup>3</sup>
LPMODE Assert Time	ton_LPMODE	100	μs	Time from assertion of LPMODE (Vin:LPMODE = Vih) until module power consumption enters lower Power Level 1
LPMODE Deassert Time	Toff_LPMODE	300	ms	Time for deassertion of LPMODE (Vin:LPMODE=Vil) until module is fully functional <sup>3,5</sup>
IntL Assert Time	ton_IntL	200	ms	Time from occurrence of condition triggering IntL until Vout:IntL = Vol
IntL Deassert Time	toff_IntL	500	μs	Time from clear on read <sup>4</sup> operation of associated flag until Vout:IntL = Voh. This includes deassert times for Rx LOS, Tx Fault and other flag bits.
Rx LOS Assert Time	ton_los	100	ms	Time from Rx LOS state to Rx LOS bit set (value=1b) and IntL asserted
Tx Fault Assert Time	ton_Txfault	200	ms	Time from Tx Fault state to Tx Fault bit set (value=1b) and IntL asserted
Flag Assert Time	ton_flag	200	ms	Time from occurrence of condition triggering flag to associated flag bit set (value=1b) and IntL asserted
Mask Assert Time	ton_mask	100	ms	Time from mask bit set(value=1b) <sup>1</sup> until associated IntL assertion is inhibited
Mask Deassert Time	toff_mask	100	ms	Time from mask bit cleared (value=0b) <sup>1</sup> until associated IntL operation resumes
Application or Rate Select Change Time	t_ratesel	100	μs	Time from change of state of Application or Rate Select Bit <sup>1</sup> until transmitter or receiver bandwidth is in conformance with appropriate specification
Power over-ride or Power-set Assert Time	ton_Pdown	100	ms	Time from P_Down bit set (value=1b) <sup>1</sup> until module power consumption enters lower Power Level 1

Power_over-ride or Power-set Deassert Time	toff_Pdown	300	ms	Time from P_Down bit cleared(value=0b) <sup>1</sup> until the module is fully functional <sup>3</sup>
--	------------	-----	----	---

**Note:**

1. Power on is defined as the instant when supply voltages reach and remain at or above the minimum specified value.
2. Fully functional is defined as IntL asserted due to data not ready bit, bit 0 byte 2 deasserted.
3. Measured from falling clock edge after stop bit of read transaction.
4. Measured from falling clock edge after stop bit of write transaction.

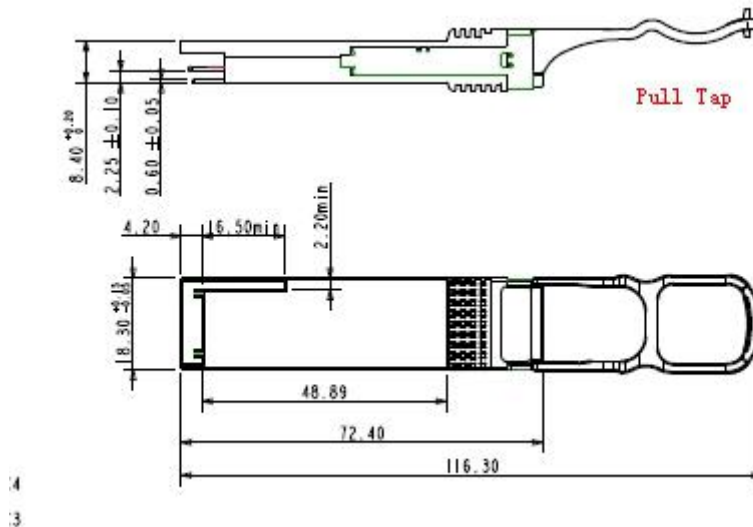

**Mechanical Dimensions**

**Figure9. Mechanical Specifications**

**ESD**

This QSFP PSM LR4 is specified as ESD threshold 1KV for high speed data pins and 2KV for all others electrical input pins, tested per MIL-STD-883, Method 3015.4 /JESD22-A114-A (HBM). However, normal ESD precautions are still required during the handling of this module. This transceiver is shipped in ESD protective packaging. It should be removed from the packaging and handled only in an ESD protected environment

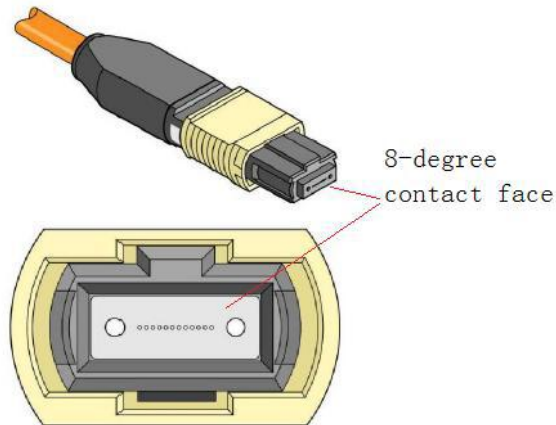

### Female MPO Connector with 8-degree End-face for this module

#### Ordering information

Part Number	Product Description
GQM-SPO400-LR4CA	40Gb/s QSFP+ PSM LR4 up to 10km, MPO connector



#### CAUTION:

Use of controls or adjustment or performance of procedures other than those specified herein may result in hazardous radiation exposure

#### Important Notice

Performance figures, data and any illustrative material provided in this data sheet are typical and must be specifically confirmed in writing by GIGALIGHT before they become applicable to any particular order or contract. In accordance with the GIGALIGHT policy of continuous improvement specifications may change without notice.

The publication of information in this data sheet does not imply freedom from patent or other protective rights of GIGALIGHT or others. Further details are available from any GIGALIGHT sales representative.

[sales@gigalight.com.cn](mailto:sales@gigalight.com.cn)  
<http://www.gigalight.com>