

Industrial 25G LWDM SFP28 40km Optical Transceiver GSS-Sx250-ERT

Features

- Hot-pluggable SFP28 form factor
- Full-duplex transceiver module
- Cooled LAN-WDM EML TOSA and APD ROSA
- Internal CDR on both transmitter and receiver channels
- Compliant with SFP28 MSA and IEEE 802.3cc 25GBASE-ER
- Compliant with CPRI/eCPRI specifications
- Data rate up to 25.78125Gbps
- Wavelengths: 1286.66, 1291.10, 1295.56, 1300.05, 1304.58, 1309.14 nm
- Reach up to 30km without FEC or 40km with FEC over SMF
- Power consumption < 2W
- Duplex LC receptacle
- Built-in digital diagnostic functions
- Operating case temperature range from -40°C to +85°C
- 3.3V power supply voltage
- RoHS compliant (lead free)



Applications

- 25GBASE-ER Ethernet Data Center Networks
- CPRI/eCPRI 5G Fronthaul Networks

Description

The Gigalight industrial 25G LWDM SFP28 40km optical transceiver (GSS-Sx250-ERT) is designed for Data Center 25GBASE-ER Ethernet and 5G Fronthaul CPRI/eCPRI links reach up to 30km without FEC or 40km with FEC over Single-Mode Fiber (SMF). Its high-performance cooled LAN-WDM EML transmitter and high-sensitivity APD receiver provide superior performance for 25G applications. The central wavelength of the LAN-WDM EML are optional with 1286.66, 1291.10, 1295.56, 1300.05, 1304.58, 1309.14 nm as members of the LAN-WDM wavelength grid defined in IEEE 802.3ba. The product is designed with form factor, optical/electrical connection and digital diagnostic interface according to the SFP28 MSA.

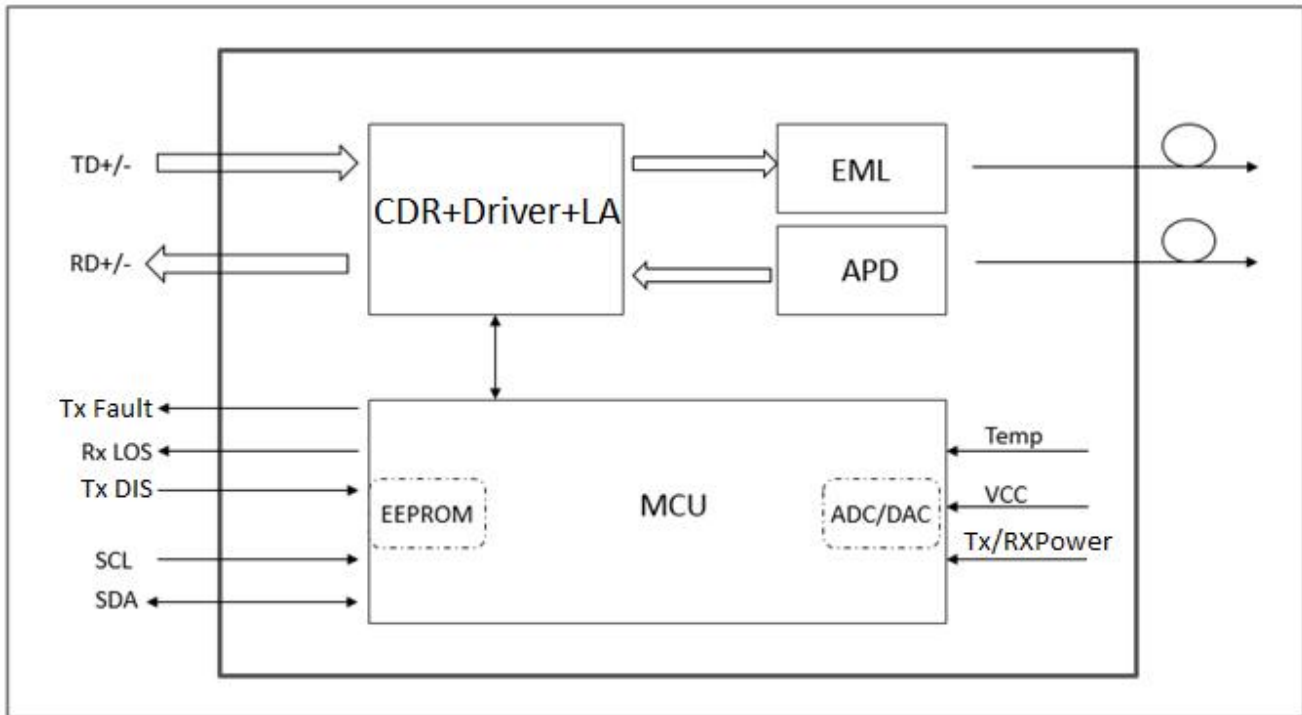

Block Diagram

Absolute Maximum Ratings

Parameter	Symbol	Min	Max	Unit
Supply Voltage	Vcc	0	3.6	V
Operating Case Temperature	Top	-40	+85	°C
Storage Temperature	Ts	-40	+85	°C
Operating Humidity	-	5	85	%
Damage Threshold, each Lane	THd	-3.0		dBm

Recommended Operating Conditions

Parameter	Symbol	Min	Typical	Max	Unit
Operating Case Temperature	Tc	-40		+85	°C
Power Supply Voltage	Vcc	3.13	3.3	3.47	V
Power Supply Current	Icc			600	mA
Data Rate, each lane			25.78125		Gb/s
Data Rate Accuracy		-100		100	ppm
Link distance with G.652(without FEC)				30	Km
Link distance with G.652(with FEC)				40	Km

Optical and Electrical Characteristics

Parameter	Symbol	Min	Typical	Max	Unit	Notes
Transmitter						
Data rate	BR		25.78		Gbps	
SDD11	TP1	CEI-28G-VSR Equation 13-19			dB	
SDC11,SCD11	TP1	CEI-28G-VSR Equation 13-20			dB	
Stressed Input Test	TP1a	CEI-28G-VSR Section 13.3.11.2.1				
Differential data input swing	$V_{IN,PP}$	150		1100	mV	
Input Differential Impedance	Z_{IN}	90	100	110	Ω	
Center Wavelength	λ_c	1285.65	1286.66	1287.69	nm	
		1290.09	1291.10	1292.13	nm	
		1294.53	1295.56	1296.59	nm	
		1299.02	1300.05	1301.09	nm	
		1303.54	1304.58	1305.63	nm	
		1308.09	1309.14	1310.19	nm	
Spectral Width (-20dB)	σ			1	nm	
Side Mode Suppression Ratio	SMSR	30			dB	
Average Output Power	P_{avg}	0		4	dBm	
Optical Modulation Amplitude		0		4	dBm	
Extinction Ratio	ER	7			dB	
Transmitter and dispersion penalty				2.7	dB	
Rin_{20OMA}				-130	dB/HZ	
Optical return loss tolerance				20	dB	
Transmitter reflectance				-26	dB	
Average Launch Power OFF transmitter	P_{off}			-30	dBm	
Transmitter eye definition {X1,X2,X3,Y1,Y2,Y3} Hit ratio 5E-5		{0.31,0.4,0.45,0.34,0.38,0.4}				1
TX Disable	Disable		2.0		Vcc	V
	Enable		0		0.8	V
TX Fault	Fault		2.0		Vcc	V
	Normal		0		0.8	V
Receiver						
Data rate	BR		25.78		Gbps	
SDD22	TP4	CEI-28G-VSR Equation 13-19			dB	
SDC22, SCD22	TP4	CEI-28G-VSR Equation 13-21			dB	

SCC22	TP4			-2	dB	
Transition Time,20% to 80%	TP4	9.5			ps	
Vertical Eye Closure(VEC)	TP4			5.5	dB	
Eye Width at E-15 probability	EW15	0.57			UI	
Eye Height at E-15 probability	EH15	228			mV	
Average Receive Power		-23		-5	dBm	
Unstressed Receiver Sensitivity (OMA)	SEN1			-17	dBm	BER=1
	SEN2			-20	dBm	BER=5
Receiver Reflectance				-26	dB	
LOS De-Assert	LOS _D		-26		dBm	
LOS Assert	LOS _A		-24		dBm	
LOS Hysteresis		0.5			dB	
Differential data output swing	Vout,PP	300		900	mV	
LOS	High	2.0		Vcc	V	
	Low			0.8	V	

Notes:

1. Transmitter eye compliant to IEEE 802.3cc 25G-ER

Timing and Electrical

Parameter	Symbol	Min.	Max.	Unit	Conditions
Tx_Disable assert time	t_off		100	μs	Rising edge of Tx_Disable to fall of output signal below 10% of nominal
Tx_Disable negate time	t_on		2	ms	Falling edge of Tx_Disable to rise of output signal above 90% of nominal. This only applies in normal operation, not during start up or fault recovery.
Time to initialize 2-wire interface	t_2w_start_up		300	ms	From power on or hot plug after the supply meeting Table 8.
Time to initialize	t_start_up		300	ms	From power supplies meeting Table 8 or hot plug or Tx disable negated during power up, or Tx_Fault recovery, until non-cooled power level I part (or non-cooled power level II part already enabled at power level II for Tx_Fault recovery) is fully operational.
Time to initialize cooled module and time to power up a cooled module to Power Level II	t_start_up_cooled		90	s	From power supplies meeting Table 8 or hot plug, or Tx disable negated during power up or Tx_Fault recovery, until cooled power level I part (or cooled power level II part during fault recovery) is fully operational. Also, from stop bit low-to-high SDA transition enabling Power Level II until cooled module is fully operational
Time to Power Up to Level II	t_power_level2		300	ms	From stop bit low-to-high SDA transition enabling power level II until non-cooled module is fully operational
Time to Power Down from Level II	t_power_down		300	ms	From stop bit low-to-high SDA transition disabling power level II until module is within power level I requirements
Tx_Fault assert	Tx_Fault_on		1	ms	From occurrence of fault to assertion of Tx_Fault
Tx_Fault assert for cooled module	Tx_Fault_on_cooled		50	ms	From occurrence of fault to assertion of Tx_Fault
Tx_Fault Reset	t_reset	10		μs	Time Tx_Disable must be held high to reset Tx_Fault
RS0, RS1 rate select timing for FC	t_RS0_FC, t_RS1_FC		500	μs	From assertion till stable output
RS0, RS1 rate select timing non FC	t_RS0, t_RS1		24	ms	From assertion till stable output
Rx_LOS assert delay	t_los_on		100	μs	From occurrence of loss of signal to assertion of Rx_LOS
Rx_LOS negate delay	t_los_off		100	μs	From occurrence of presence of signal to negation of Rx_LOS

Diagnostics

Parameter	Range	Unit	Accuracy	Calibration
Temperature	0 to +70	°C	±5°C	Internal / External
Voltage	3.0 to 3.6	V	±3%	Internal / External
Bias Current	0 to 100	mA	±10%	Internal / External
TX Power	0 to 4	dBm	±3dB	Internal / External
RX Power	-23 to -5	dBm	±3dB	Internal / External

Digital Diagnostic Memory Map

The transceivers provide serial ID memory contents and diagnostic information about the present operating conditions by the 2-wire serial interface (SCL, SDA).

The diagnostic information with internal calibration or external calibration all are implemented, including received power monitoring, transmitted power monitoring, bias current monitoring, supply voltage monitoring and temperature monitoring.

The digital diagnostic memory map specific data field defines as following.

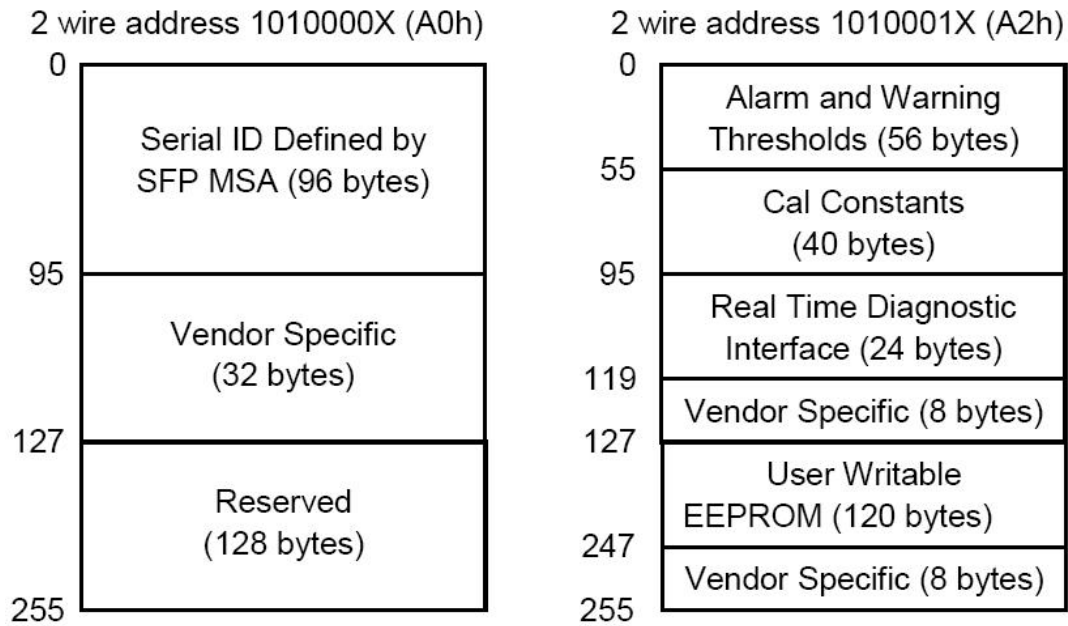

Pin Definitions

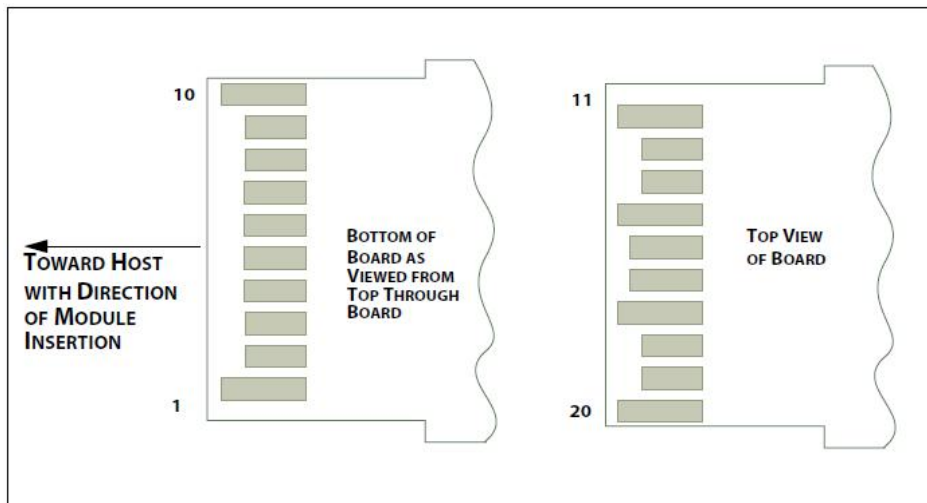
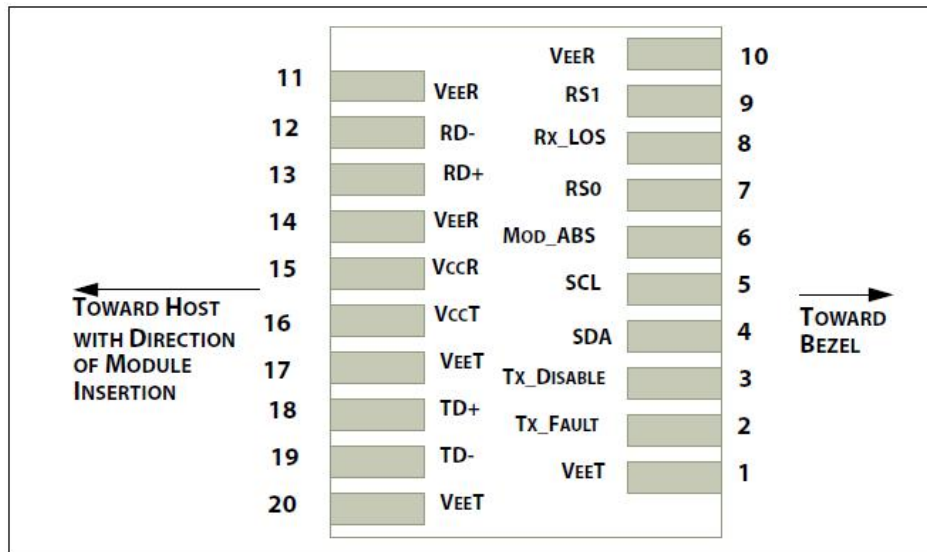

Pin Descriptions

PI N	Logic	Symbol	Name / Description	Note
1		VeeT	Module Transmitter Ground	1
2	LVTTTL-O	TX_Fault	Module Transmitter Fault	2
3	LVTTTL-I	TX_Dis	Transmitter Disable; Turns off transmitter laser output	
4	LVTTTL-I/O	SDA	2-Wire Serial Interface Data Line	2
5	LVTTTL-I	SCL	2-Wire Serial Interface Clock	2
6		MOD_ABS	Module Definition, Grounded in the module	
7	LVTTTL-I	RS0	Receiver Rate Select	
8	LVTTTL-O	RX_LOS	Receiver Loss of Signal Indication Active LOW	
9	LVTTTL-I	RS1	Transmitter Rate Select (not used)	
10		VeeR	Module Receiver Ground	1
11		VeeR	Module Receiver Ground	1
12	CML-O	RD-	Receiver Inverted Data Output	
13	CML-O	RD+	Receiver Data Output	
14		VeeR	Module Receiver Ground	1
15		VccR	Module Receiver 3.3 V Supply	
16		VccT	Module Receiver 3.3 V Supply	
17		VeeT	Module Transmitter Ground	1
18	CML-I	TD+	Transmitter Non-Inverted Data Input	
19	CML-I	TD-	Transmitter Inverted Data Input	
20		VeeT	Module Transmitter Ground	1

Notes:

1. Module ground pins GND are isolated from the module case.
2. Shall be pulled up with 4.7K-10Kohms to a voltage between 3.15V and 3.45V on the host board.

Recommended Interface Circuit

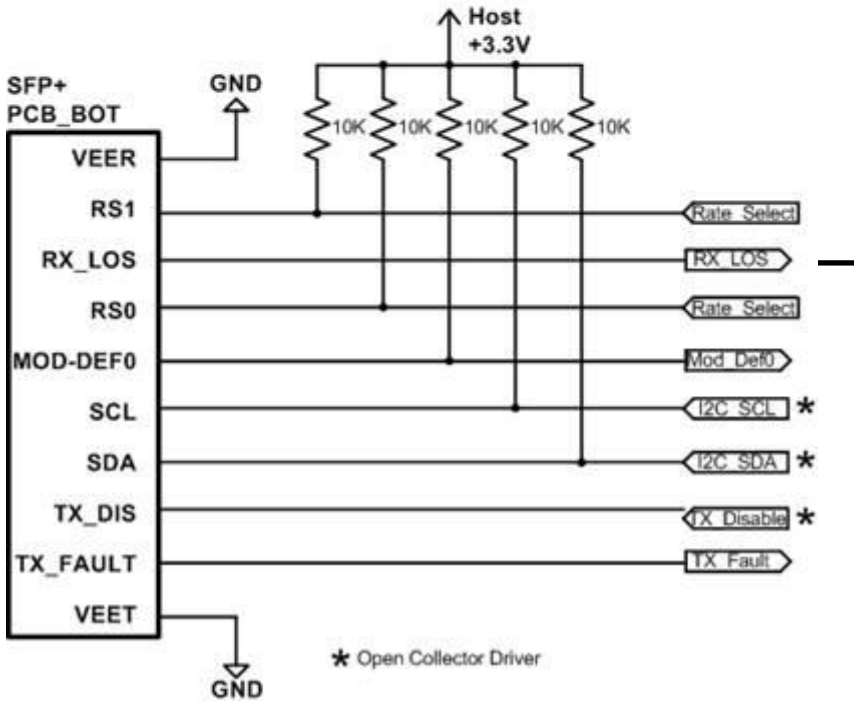
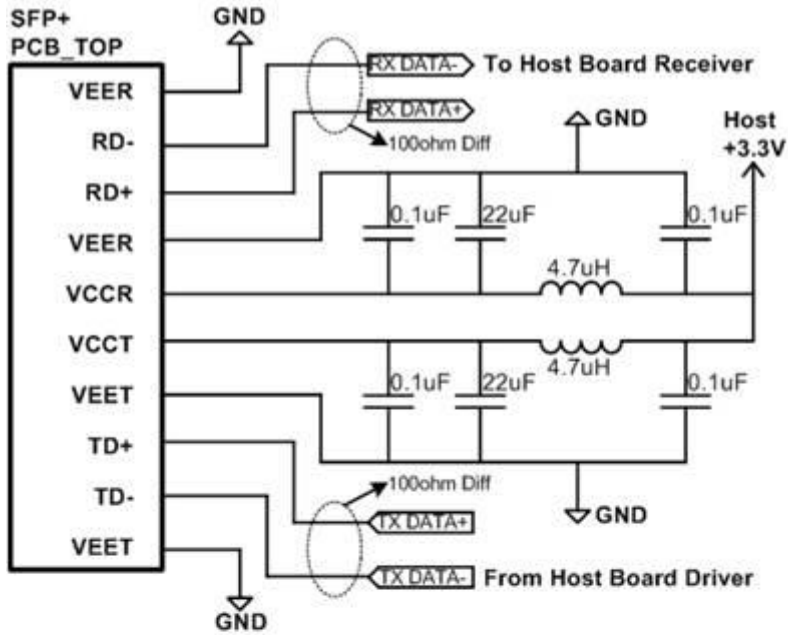

Mechanical Dimensions

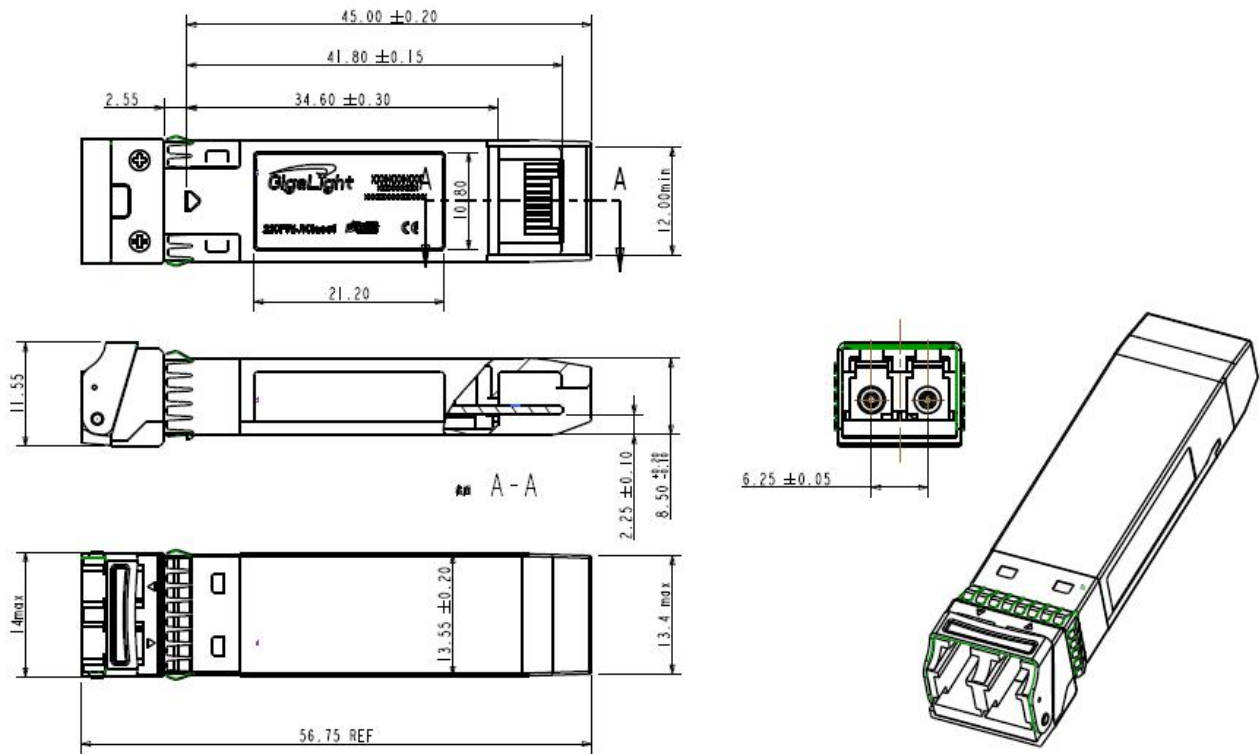

Ordering information

Part Number	Product Description
GSS-Sx250-ERT	25G LWDM SFP28, 25.78125Gbps, 1286-1309nm, 30km/40km, -40°C to +85°C

Email: sales@gigalight.com

Website: www.gigalight.com