

## GIGALIGHT 70KM DWDM SFP+ Optical Transceiver GDP-XX192-07T

### Features

- ◆ Hot-pluggable SFP+ footprint
- ◆ Supports 9.8 to 10.3 Gb/s
- ◆ Link length up to 70km on G.652D SMF
- ◆ Suitable for use in 100GHz channel spacing DWDM systems
- ◆ Operating case temperature range: -40°C to +85°C
- ◆ Cooled EML transmitter and APD receiver
- ◆ Maximum power dissipation <2W (Typical 1.4W)
- ◆ Single 3.3V power supply
- ◆ Duplex LC connector
- ◆ Built-in digital diagnostic interface
- ◆ RoHS compliant (lead free)



### Applications

- ◆ CPRI standard
- ◆ 10G Ethernet
- ◆ SDH/SONET
- ◆ 10G Fiber Channel
- ◆ ITU-T G.698.1 DS100S1-2Dz(C)

### Description

The Gigalight DWDM 70km SFP+ Transceiver is a “Limiting module”, designed for CPRI, 10GBASE, SDH/SONET and 10G Fiber Channel applications, link length up to 70km on G.652D SMF.

They are compliant with SFF-8431 Rev 4.1, SFF-8432 and SFF-8472 Rev 10.3.

The transmitter section incorporates a cooled EML laser, and the receiver section consists of a APD photodiode integrated with TIA.

Digital diagnostics functions are available via a 2-wire serial interface, as specified in SFF-8472, which allows real-time access to device operating parameters such as case temperature, laser bias current, transmitted optical power, received optical power and module supply voltage.

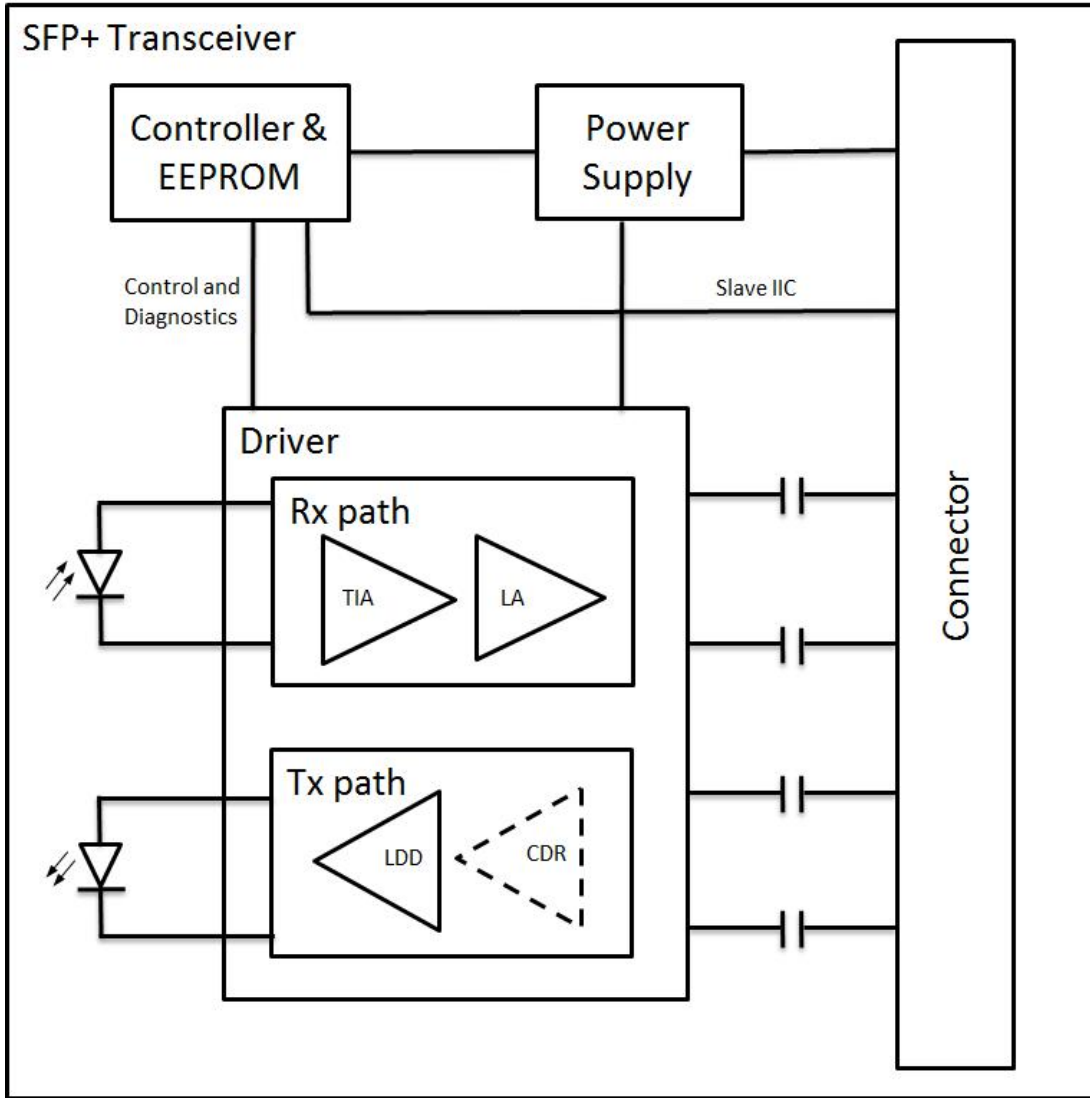

Figure1. Module Block Diagram

**Absolute Maximum Ratings**

Parameter	Symbol	Min	Max	Unit
Supply Voltage	Vcc	-0.5	+3.8	V
Storage Temperature	Tst	-40	+85	°C
Relative Humidity	Rh	0	85	%
Max Link Length	Lmax		70	km

**Operating Conditions**

Parameter	Symbol	Min	Typical	Max	Unit
Supply Voltage	Vcc	3.13	3.3	3.47	V
Supply current	Icc	-	420	606	mA
Operating Case temperature	Tca	-40	-	+85	°C
Module Power Dissipation	Pm	-	1.4	2	W

**Transmitter Specifications – Optical**

Parameter	Symbol	Min	Typical	Max	Unit	Ref.
Center Wavelength-End of life	$\lambda_c$	$\lambda_c - 100$	$\lambda_c$	$\lambda_c + 100$	pm	1
Spectral Width (-20dB)	$\Delta\lambda_{20}$	-	-	0.3	nm	
Average Optical Power	AOP	0	-	+4	dBm	2
Side Mode Suppression Ratio	SMSR	30	-	-	dB	
Optical Transmit Power (disabled)	Poff	-	-	-30	dBm	
Extinction Ratio	ER	8.2	-	-	dB	
Relative Intensity Noise	RIN	-	-	-128	dB/Hz	
Optical Return Loss Tolerance	Orl	-	-	21	dB	

**Notes:**

1. Wavelength stability is achieved within 60 seconds (max) of power up.
2. Minimum OMA = -2.4 dBm.

**Receiver Specifications – Optical**

Parameter	Symbol	Min	Typical	Max	Unit	Ref.
Input Operating Wavelength	$\lambda$	1260	-	1620	nm	
Average receive power	Pavg	-24	-	-5	dBm	
Sensitivity (0km, 9.8~10.3Gbps)	Rsen1	-	-	-24	dBm	2
Sensitivity (70KM, 9.8~10.3Gbps)	Rsen3			-22	dBm	2
Maximum Input Power	RX-overload	-5	-		dBm	
Loss of Signal Asserted	LOS <sub>A</sub>	-34	-	-	dBm	
LOS De-Asserted	LOS <sub>D</sub>	-	-	-24	dBm	
LOS Hysteresis	LOS <sub>H</sub>	0.5	-		dB	

**Notes:**

[1] Measured with conformance test signal for BER =  $10^{-12}$ . The stressed sensitivity values in the table are for system level BER measurements which include the effects of CDR circuits. It is recommended that at least 0.4 dB additional margin be allocated if component level measurements are made without the effects of CDR circuits.

[2] Measured with worst ER=8.2dB;  $2^{31} - 1$  PRBS. BER <  $10^{-12}$

**Transmitter Specifications – Electrical**

Parameter	Symbol	Min	Typical	Max	Unit
Bit Rate	BR	9.8		10.3125	Gbps
Input differential impedance	Rim	-	100	-	$\Omega$
Differential data Input	VtxDIFF	120	-	850	mV
Transmit Disable Voltage	VD	2.0	-	Vcc3+0.3	V
Transmit Enable Voltage	Ven	0	-	+0.8	V
Transmit Disable Assert Time	Vn	-	-	100	us

**Receiver Specifications – Electrical**

Parameter	Symbol	Min	Typical	Max	Unit
Bit Rate	BR	9.8		10.3125	Gbps
Differential Output Swing	Vout P-P	350	-	850	mV
Rise/Fall Time	Tr / Tf	24	-	-	ps
Loss of Signal –Asserted	VOH	2	-	Vcc3+0.3-	V
Loss of Signal –Negated	VOL	0	-	+0.4	V

**Digital Diagnostic Functions**

Parameter	Symbol	Min.	Max	Unit	Notes
<b>Accuracy</b>					
Transceiver Temperature	DMI_Temp	-3	+3	°C	
TX Output optical power	DMI_TX	-2	+2	dB	
RX Input optical power	DMI_RX	-2	+2	dB	
Transceiver Supply voltage	DMI_VCC	-3%	+3%	V	Full operating
Bias current monitor	DMI_Ibias	-10%	10%	mA	
<b>Dynamic Range</b>					
Transceiver Temperature	DMI_Temp	-40	+85	°C	
TX Output optical power	DMI_TX	-1	+5	dBm	
RX Input optical power	DMI_RX	-28	-5	dBm	
Transceiver Supply voltage	DMI_VCC	3.0	3.6	V	
Bias current monitor	DMI_Ibias	0	120	mA	

**C-band λc Wavelength Guide**

ITU Channel Product Code	Frequency(THz)	Wavelength	ITU Channel Product Code	Frequency(THz)	Wavelength
17	191.7	1563.86	40	194.0	1545.32
18	191.8	1563.05	41	194.1	1544.53
19	191.9	1562.23	42	194.2	1543.73
20	192.0	1561.42	43	194.3	1542.94
21	192.1	1560.61	44	194.4	1542.14
22	192.2	1559.79	45	194.5	1541.35
23	192.3	1558.98	46	194.6	1540.56
24	192.4	1558.17	47	194.7	1539.77
25	192.5	1557.36	48	194.8	1538.98
26	192.6	1556.55	49	194.9	1538.19
27	192.7	1555.75	50	195.0	1537.40
28	192.8	1554.94	51	195.1	1536.61

29	192.9	1554.13	52	195.2	1535.82
30	193.0	1553.33	53	195.3	1535.04
31	193.1	1552.52	54	195.4	1534.25
32	193.2	1551.72	55	195.5	1533.47
33	193.3	1550.92	56	195.6	1532.68
34	193.4	1550.12	57	195.7	1531.90
35	193.5	1549.32	58	195.8	1531.12
36	193.6	1548.51	59	195.9	1530.33
37	193.7	1547.72	60	196.0	1529.55
38	193.8	1546.92	61	196.1	1528.77
39	193.9	1546.12			

Table 1. Product ordering codes: the central wavelength is defined as per ITU-T 694.1

### Pin Descriptions

Pin	Symbol	Name/Description
1	VEET [1]	Transmitter Ground
2	Tx_FAULT [2]	Transmitter Fault
3	Tx_DIS [3]	Transmitter Disable. Laser output disabled on high or open
4	SDA [2]	2-wire Serial Interface Data Line
5	SCL [2]	2-wire Serial Interface Clock Line
6	MOD_ABS [4]	Module Absent. Grounded within the module
7	RS0 [5]	Rate Select 0
8	RX_LOS [2]	Loss of Signal indication. Logic 0 indicates normal operation
9	RS1 [5]	Rate Select 1
10	VEER [1]	Receiver Ground
11	VEER [1]	Receiver Ground
12	RD-	Receiver Inverted DATA out. AC Coupled
13	RD+	Receiver DATA out. AC Coupled
14	VEER [1]	Receiver Ground
15	VCCR	Receiver Power Supply
16	VCCT	Transmitter Power Supply
17	VEET [1]	Transmitter Ground
18	TD+	Transmitter DATA in. AC Coupled
19	TD-	Transmitter Inverted DATA in. AC Coupled
20	VEET [1]	Transmitter Ground

#### Notes:

[1] Module circuit ground is isolated from module chassis ground within the module.

[2].should be pulled up with 4.7k – 10k ohms on host board to a voltage between 3.15V and 3.6V.

[3]Tx\_Disable is an input contact with a 4.7 kΩ to 10 kΩ pullup to VccT inside the module.

[4]Mod\_ABS is connected to VeeT or VeeR in the SFP+ module. The host may pull this contact up to Vcc\_Host with a resistor in the range 4.7 kΩ to 10 kΩ. Mod\_ABS is asserted “High” when the SFP+ module is physically absent from a host slot.

[5] RS0 and RS1 are module inputs and are pulled low to VeeT with > 30 kΩ resistors in the module.

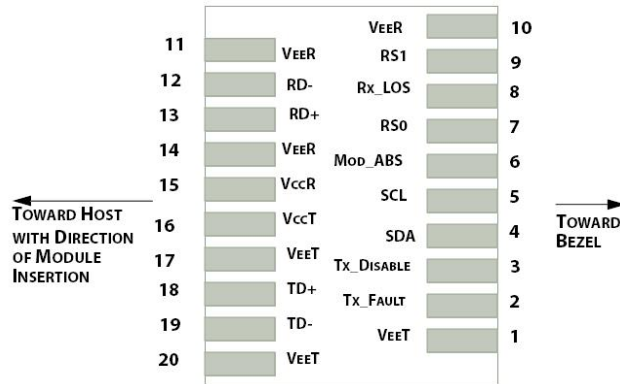

Figure 2. Electrical Pin-out Details

### Host Board SFP+ Connector Recommendations

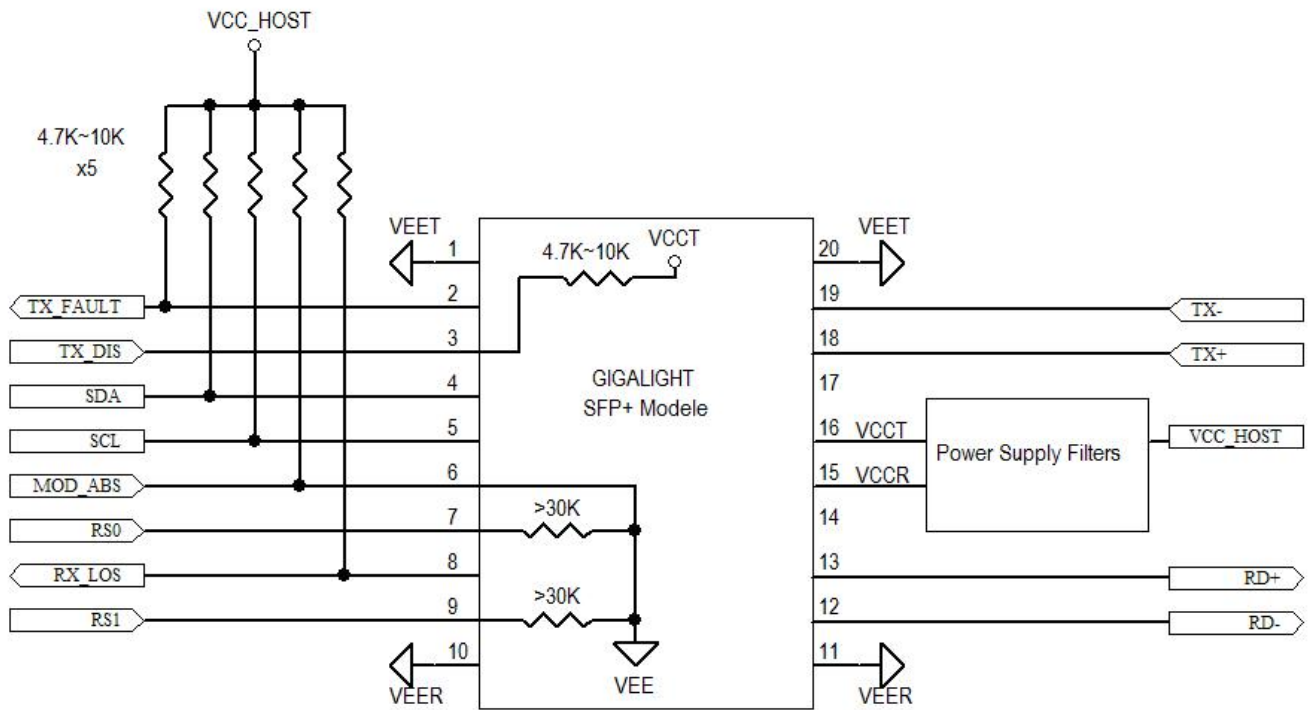

Figure 4. Host-Module Interface

## Mechanical Dimensions

Gigalight GDP-XX192-07T SFP+ Transceiver are compatible with the SFF-8432 specification for improved pluggable form factor, and shown here for reference purposes only. Bail color is white.

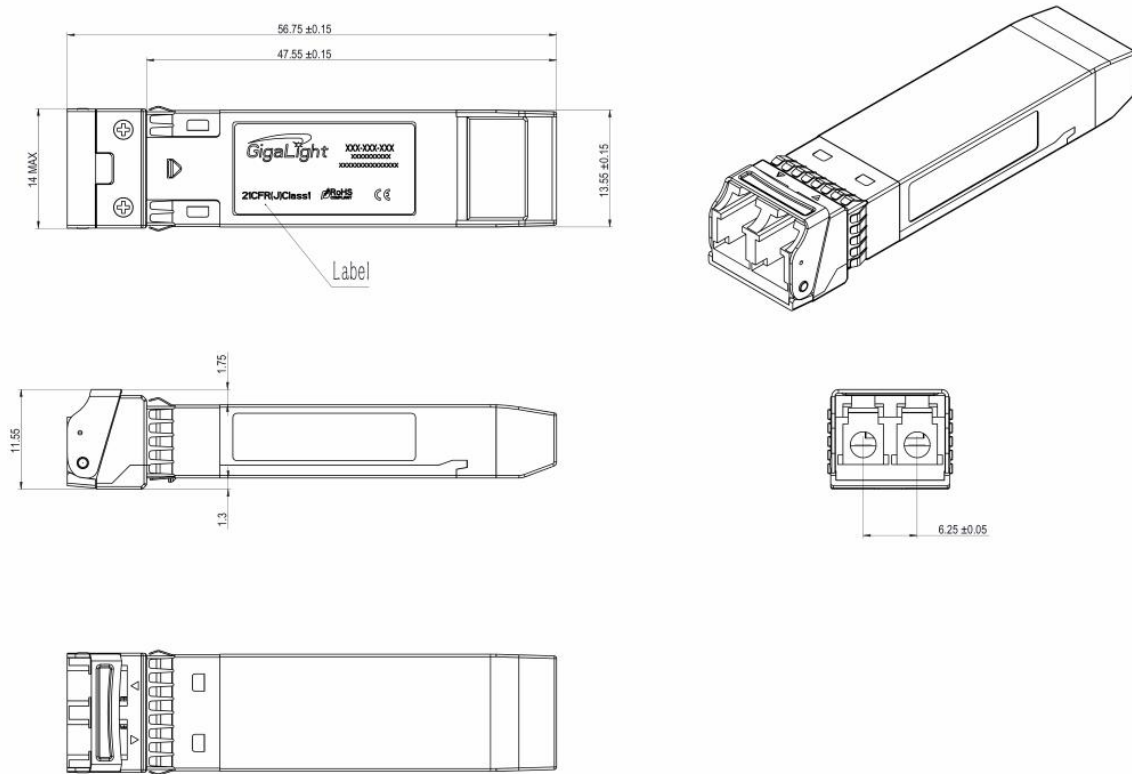

Figure5. Mechanical Specifications

## Regulatory Compliance

GIGALIGHT SFP+ transceiver is designed to be Class I Laser safety compliant and is certified per the following standards:

Feature	Standard
Laser Safety	IEC 60825-1:2014 (Third Edition)
Environmental protection	2011/65/EU
CE EMC	EN55032: 2015 EN55035: 2017 EN61000-3-2:2014 EN61000-3-3:2013
FCC	FCC Part 15, Subpart B; ANSI C63.4-2014

**Ordering information**

Part Number	Product Description
GDP-XX192-07T	XX= ITU Grid 18~61, 10Gbps, 70km DWDM SFP+, -40°C ~ +85°C

**References**

1. "Specifications for Enhanced Small Form Factor Pluggable Module SFP+", SFF-8431, Rev 4.1, July 6, 2009.
2. "Improved Pluggable Formfactor", SFF-8432, Rev 4.2, Apr 18, 2007
3. IEEE802.3ae – 2002
4. "Diagnostic Monitoring Interface for Optical Transceivers" SFF-8472, Rev 10.3, Dec 1, 2007

**Important Notice**

Performance figures, data and any illustrative material provided in this data sheet are typical and must be specifically confirmed in writing by GIGALIGHT before they become applicable to any particular order or contract. In accordance with the GIGALIGHT policy of continuous improvement specifications may change without notice.

The publication of information in this data sheet does not imply freedom from patent or other protective rights of GIGALIGHT or others. Further details are available from any GIGALIGHT sales representative.

E-mail: [sales@gigalight.com.cn](mailto:sales@gigalight.com.cn)

Web : <http://www.gigalight.com.cn>

**Revision History**

Revision	Date	Description
V0	Mar. 28, 2019	Advance Release.